

MODEL 255

VOLT-AMPERE-WATT METER

(Serial Nos greater than 30,000)

(212) 255-2940

**clarke·hess**

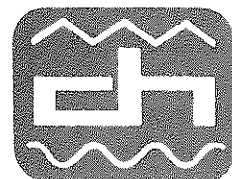

COMMUNICATION RESEARCH CORP.  
17 WEST 17th STREET • NEW YORK, N.Y. 10011

Copyright 1983 by CLARKE-HESS  
Communication Research Corporation

The information in this manual is intended to aid in the operation and maintenance of the Model 255 or 256 Digital V-A-W Meter and is not to be used otherwise or reproduced without the written consent of the CLARKE-HESS Communication Research Corporation.

## TABLE OF CONTENTS

WARRANTY

LIST OF ABBREVIATIONS AND CONDENSATIONS USED IN THE MANUAL

SPECIFICATIONS

### I. BASIC FEATURES, CONTROLS, AND CONDENSED OPERATING INSTRUCTIONS

- 1-1. Introduction
- 1-2 Basic Controls, Inputs and Outputs
- 1-3 Special Features
- 1-4 Condensed Operating Instructions - Voltage and Current
- 1-5 Condensed Operating Instructions - Power
- 1-6 Condensed Operating Instructions - Power Factor
- 1-7 Three Phase Power Measurements

### II. CALIBRATION: MEASUREMENT AND ADJUSTMENT

- 2-1 Calibration Equipment and Standards
- 2-2 Calibration Measurement - Zero
- 2-3 Calibration Adjustment - Zero
- 2-4 Calibration Measurement - Current
- 2-5 Calibration Adjustment - Current
- 2-6 Calibration Measurement - Voltage
- 2-7 Calibration Adjustment - Voltage
- 2-8 Calibration Measurement - Power
- 2-9 Calibration Adjustment - Power
- 2-10 Calibration Measurement - Power Factor
- 2-11 Calibration Adjustment - Power Factor

### III. THEORY OF OPERATION

- 3-0 General Operation
- 3-1 Current Attenuator Board
- 3-2 Voltage Attenuation Board and Box
- 3-3 Display Board
- 3-4-0 Analog Section - General
- 3-4-1 Amplifier/Multiplier/Input CMOS Switches
- 3-4-2 Auto-Zero Circuitry (Amplifier/Multiplier)
- 3-4-3 Analog/Digital Conversion
- 3-4-4 Power Factor Detector
- 3-4-5 Square Root Generator
- 3-4-6 Input Overload Detectors

- 3-5-0. Clocks and Timing - General
- 3-5-1. Low Frequency Clock, LFC
- 3-5-2. High Frequency Clock, HFC
- 3-5-3. Active
- 3-5-4. Signal
- 3-5-5. Reference
- 3-5-6. Load Latch Pulse, LL, and NOT LL
- 3-5-7. Polarity Signals
- 3-6-0. Digital Control Circuitry
- 3-6-1. Decimal Point, Function, and Full Scale Memories
- 3-6-2. Input Decoding Circuitry
- 3-6-3. Drivers for the CMOS Switches in IC11, 12, and 13)
- 3-7. "Dynamic" Switch Drivers
- 3-8-0. Over and Under Range Circuitry
- 3-8-1. Output Over Range
- 3-8-2. Input Under Range
- 3-9-0. Power Supplies
- 3-9-1. +5 V Supply
- 3-9-2.  $\pm 15$  V Supplies
- 3-9-3. +8 V and -6 V Supplies
- 3-10. Options, including IEEE-488 bus, analog output, and range extension.

#### IV. REPAIR AND ADJUSTMENT

- 4-0. Introduction
- 4-1. Power Supply Voltages
- 4-2. Input Protection
- 4-3-1. Analog Section - General
- 4-3-2. Auto-Zero
- 4-3-3. Integrator/Comparator
- 4-4. Clock and Timing Circuitry
- 4-5. Digital Control Logic/Specialized Circuits
- 4-6-0. Adjustment Procedure After IC Replacement in the Analog Section
- 4-6-1. Input DC Offset Controls, P2, 12, and 130
- 4-6-2. Multiplier Crossover Controls
- 4-6-3. Multiplier DC Offset Controls
- 4-6-4. Multiplier Linearity
- 4-6-5. Other Controls

#### V. REPLACEMENT PARTS

#### VI. DIAGRAMS

## WARRANTY

All CLARKE-HESS instruments are warranted against defects in materials and workmanship. This warranty applies for one year from the date of delivery of the instruments. The CLARKE-HESS Communication Research Corp. will repair or replace instruments that prove to be defective during the warranty period. For such repair or replacement, the instrument must be returned to us (See Section 4-0 for details) and must, in our opinion, not have been subjected to unreasonable usage or internal reworking. No other warranty is expressed or implied.

CLARKE-HESS assumes no liability for secondary charges or for consequential damages.

ABBREVIATIONS AND CONDENSATIONS  
USED IN THIS MANUAL

|       |                                   |
|-------|-----------------------------------|
| AC    | Alternating Current               |
| C     | Capacitor                         |
| COM   | Common                            |
| CR    | Crystal Rectifier - Diode         |
| D     | Diode                             |
| DC    | Direct Current                    |
| FS    | Full Scale                        |
| (ftf) | (from the front)                  |
| HFC   | High Frequency Clock              |
| I     | Current                           |
| IC    | Integrated Circuit                |
| LED   | Light Emitting Diode              |
| LFC   | Low Frequency Clock               |
| LL    | Load Latch Pulse                  |
| NGT   | Negative Going Transition         |
| NP    | Negative Polarity Pulse           |
| PF    | Power Factor                      |
| PGT   | Positive Going Transition         |
| PP    | Positive Polarity Pulse           |
| PROM  | Programmable Read Only Memory     |
| Q     | Transistor or Latch Output Signal |
| R     | Resistor                          |
| S     | Switch                            |
| V     | Voltage                           |
| VA    | Volt Amperes                      |

**ACCURACY AND BANDWIDTH**

**VOLTAGE and CURRENT**

Readings between 1/12 and 1.7 times Full Scale

| Frequency Range <sup>(3)</sup> | Accuracy                         |
|--------------------------------|----------------------------------|
| dc to 30 Hz <sup>(1)</sup>     | ± 0.6% Full Scale ± 0.4% Reading |
| 30 Hz to 100 kHz               | ± 0.4% Full Scale ± 0.2% Reading |
| 100 kHz to 300 kHz             | ± 0.6% Full Scale ± 0.6% Reading |

**POWER**

$$\text{Power Factor} = \frac{\text{Power}}{\text{Input V.A.}} \geq 0.5$$

| Input V.A. Range    | V <sub>range</sub> | dc to 30 Hz <sup>(1)</sup> | 30 Hz - 50 kHz         | 50 kHz - 100 kHz       |
|---------------------|--------------------|----------------------------|------------------------|------------------------|
| less than 1.5       |                    | ± 0.6% F.S.<br>± 0.4% V.A. | 0.4% F.S.<br>0.2% V.A. | 0.6% F.S.<br>0.6% V.A. |
| between 1.5 and 2.5 |                    | ± 1% V.A.                  | 0.6% V.A.              | 1% V.A.                |

$$\text{Power Factor}^{(2)} = \frac{\text{Power}}{\text{Input V.A.}} < 0.5$$

| Input V.A. Range    | V <sub>range</sub> | 30 Hz - 25 kHz             | 25 kHz - 50 kHz        | 50 kHz - 100 kHz       |
|---------------------|--------------------|----------------------------|------------------------|------------------------|
| less than 1.5       |                    | ± 0.4% F.S.<br>± 0.2% V.A. | 0.5% F.S.<br>0.5% V.A. | 0.7% F.S.<br>0.8% V.A. |
| between 1.5 and 2.5 |                    | ± 0.6% V.A.                | 1% V.A.                | 1.5% V.A.              |

Terms: V.A. means the actual product of the input Volts and Amperes as measured on the model 255.

<sup>1</sup>range V<sub>range</sub> means the Full Scale (F.S.) value of the POWER "range". This is the product of the Current range value and the Voltage range value.

Power Factor is defined as the ratio of the measured POWER to the measured VOLT-AMPERES. In the case where both current and voltage are sinusoidal, then the Power Factor is the cosine of the phase angle between the voltage and the current.

**POWER x 10**

In cases where BOTH the input Voltage and the input current are less than 40% of their full scale values, the POWER x 10 scale allows an additional decade of resolution. The decimal point is automatically adjusted to give a direct reading of power. The measurement accuracy in Watts or milliwatts remains as stated for POWER.

**POWER FACTOR (Sine Wave Inputs ONLY)**

"Sinusoidal like" inputs between 30 Hz and 25 kHz. Current and Voltage inputs individually each less than 1.7 full scale. Input Voltage-Ampere product between 1/3 and three times the corresponding Power full scale value.

$$\pm 3.0\% \text{ of Full Scale}$$

**CREST FACTOR**

Except for the top voltage and current ranges (which are amplitude restricted) the Model 255 will measure pulse or "spike" inputs with peak values of 3.5 times the full scale may be seven times the full scale d-c level.) (Peak to Peak values around a zero average value, may be seven times the full scale d-c level).

**NOTES:**

(1) Additional internal filtering will be necessary to prevent the display from "tracking" the input for input frequencies below 10 Hz. Provision has been made for the easy addition of such filtering.

(2) In the Model 255/256 the two COMMON terminals are connected together internally. (THIS WAS NOT TRUE IN EARLIER VERSIONS). In normal usage the meter is connected so that the load current flows through the internal shunt and the meter voltage measures the sum of the load and the shunt voltage drops. Thus the POWER reading is the load power plus I<sup>2</sup>r, where r is the shunt resistance. In high power factor situations the I<sup>2</sup>r correction term is usually negligible. In low power factor situations the I<sup>2</sup>r term may make up 90% of the reading.

(3) 5A scale specified to 200 kHz only

**RESOLUTION - USEFUL RANGE  
RMS**

| Nominal FULL SCALE | LOWER LIMIT / UPPER LIMIT | RESOLUTION |
|--------------------|---------------------------|------------|
| 20 V               | 1.6 V / 34 V              | 10 mV      |
| 200 V              | 16 V / 340 V              | 100 mV     |
| 1000 V             | 83 V / 1000 V             | 1 V        |
| 5 mA               | 400 uA / 8.5 mA           | 1 uA       |
| 50 mA              | 4 mA / 85 mA              | 10 uA      |
| 500 mA             | 40 mA / 850 mA            | 100 uA     |
| 5000 mA            | 400 mA / 7.5 A            | 1 mA       |

**INPUT IMPEDANCES / PROTECTION**

| RANGE                  | INPUT IMPEDANCE                             | PROTECTION and/or LIMITS |
|------------------------|---|--------------------------|
| 20 V, 200 V            | 5 Megohm / 6 pF                             | 2 kV-peak input          |
| 1000 V                 | 5 Megohm / 6 pF                             | 2 kV-peak input          |
| 5 mA, 50 mA and 500 mA | 20 ohm / 2.0 ohm / 0.33                     | 1 1/2 Amp "FAST" FUSE    |
| 5 Ampere               | 28 milliohm (includes internal connections) | 20 Amp peak              |

At frequencies up to 600 Hz the COMMON terminals may be operated up to 250 V rms (400 V peak) above the grounded metal case.

**DISPLAYS, OUTPUTS, AND CONTROLS**

The Model 255 has a four digit display with full scale values of 5000, 2000, and 1000 depending upon the function being displayed.

The numeric display is made up of four identical 10.9 mm (0.43 inch) high, seven segment, high efficiency, LED units mounted in sockets. A non-glare, optically matched, filter covers the display. Decimal point placement is automatic. Four separate LEDs indicate NEGATIVE power or power factor readings, INPUT OVERLOAD, OUTPUT OVERLOAD, and MILLIWATTS.

The BCD equivalent of each display module is held in a separate latch. An isolated BCD or an isolated IEEE-488 output is available. An isolated switch closure or an isolated IEEE-488 control of FUNCTIONS is available.

The seven position FUNCTION switch provides ON/OFF control, the selection of the five different FUNCTIONS (I, V, P, P x 10, and Power Factor) and a REMOTE position. In REMOTE any FUNCTION may be selected by an appropriate contact closure that is capable of "sinking" 1.0 mA to ground.

**MEASUREMENT RATE**

The measurement rate and the display rate are locked to the power line frequency and are normally set at 10 readings/second (60 Hertz operation) or at 8.33 readings/second (50 Hertz operation). Other "line locked" rates are possible as well as the use of an external clock to control the timing.

**TEMPERATURE**

Operating Temperature Range: 0° to 50°C  
Specified Accuracy : 15° to 35°C

**DIMENSIONS**

Width 290 mm. (11.4 inches) Height 132 mm. (5.2 inches)  
Depth 330 mm. (13 inches)

WEIGHT 4.1 kg. (9 lbs.) **RACK MOUNT AVAILABLE**

**POWER REQUIREMENTS**

95-105 V or 105-125 V or 210-240 V, 50-60 Hz.  
Specify line voltage and line frequency when ordering.

# VOLT -AMPERE -WATT METER

MODEL 255/256\*

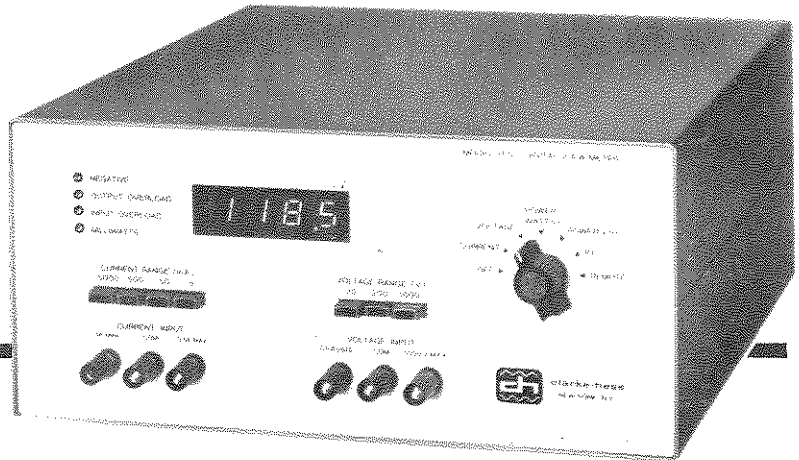

## TRUE RMS/WIDE BANDWIDTH

The Model 255 digital V-A-W meter provides TRUE RMS measurements of VOLTAGE, CURRENT, and POWER. These measurements are essentially independent of the waveshape and of the power factor from DC up to frequencies of hundreds of kilohertz. Voltage and current readings are typically within 1% to 400 kHz for sine waves. The power in a 100 kHz square wave may normally be measured within 2%.

## WIDE MEASUREMENT RANGE AMPLE RESOLUTION

The Model 255 provides FOUR full scale current ranges from 5 mA to 5 A, THREE full scale voltage ranges from 20 V to 1000 V., TWELVE full scale power ranges from 100 mW to 5000 W and TWELVE, increased resolution POWER X10 ranges from 10.00 mV to 500.0 W.

A full four digit display provides  $\pm 1$  digits of resolution for full scale ranges corresponding to 1000, 2000, or 5000 digits.

## ISOLATED OUTPUTS AND PROGRAMMING

The meters have optically isolated, digital options of:

- A. Parallel, four digit BCD output
- B. Remote control of FUNCTIONS
- C. IEEE-488 Talker/Listener Board.

The meters have an optional isolated ANALOG output. One volt output for a Full Scale display reading.

## CURRENT OR VOLTAGE RANGE EXTENSION

Full Scale CURRENT ranges down to 50.00  $\mu$ A or VOLTAGE ranges down to 1.000 V or 2.000 V are possible. External broadband shunts or transformers allow CURRENT extension to 50.00 A or 500.0 A. External voltage dividers allow VOLTAGE extension to 3500 V. Full Scale POWER for each case is equal to the VOLTAGE X CURRENT product.

## DEALS WITH MANY DIFFICULT MEASUREMENTS

The Model 255 is ideally suited to measuring almost any non-sinusoidal and/or low power factor waveshape. Typical uses are in connection with SWITCHING POWER SUPPLIES, TRANSFORMER LOSSES, FLUORESCENT LAMP BALLASTS, R-C FILTER RECTIFIER CIRCUITS, SCR CIRCUITS, MERCURY-ARC LAMP CIRCUITS, SERVO SYSTEMS, MOTOR TESTING, ULTRASONICS, MOV LOSS TESTING, AUTOMATIC TEST EQUIPMENT, SODIUM LAMP BALLASTS, FERRITE CORE LOSSES, TELEVISION SET LOSSES, AND ELECTRIC AUTOMOBILE EFFICIENCY MEASUREMENTS.

## EASY TO USE/HARD TO DAMAGE

The Model 255 is an all solid state, digital readout instrument. The V-A-W meter is complete, self contained instrument that is easy to use, hard to damage, easy to service, and easy to maintain.

## LOW CIRCUIT LOADING

An input impedance of five Megohms for the VOLTAGE terminals coupled with a full scale voltage drop of 100 millivolts across the CURRENT terminals cause negligible circuit loading or errors in most practical cases.

## PACKAGING/PROTECTION

The Model 255 is housed in a heavy duty aluminum case. The three lowest current range shunts are also diode and fuse protected.

\*The Model 256 differs from the Model 255 by having a 100.0 V range instead of a 1000 V range and by having the CURRENT input fuse located on the front panel instead of internal to the instrument.

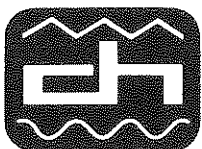

**clarke-hess** COMMUNICATION RESEARCH CORP.

17 WEST 17<sup>TH</sup> STREET • NEW YORK, N.Y. 10011 • (212) 255-2940



## I. BASIC FEATURES, CONTROLS, AND CONDENSED OPERATING INSTRUCTIONS

### 1-1. INTRODUCTION

The V-A-W Meter is a electronically sophisticated but easy to use solid state instrument.

This chapter of the Instruction Manual outlines the basic features of the instrument, the controls and terminals available on the instrument, and the configurations and connections necessary to make measurements with it.

Later chapters of the manual contain, the performance tests and calibration procedures, the theory of operation, repair procedures, the parts lists, and the set of schematic diagrams.

### 1-2. BASIC CONTROLS, INPUTS AND OUTPUTS.

The picture at the left shows the front panel of the Model 255.

The front panel CONTROLS consist of the following:

The seven position rotary FUNCTION SELECTOR switch.

The four CURRENT range pusbuttons.

The three VOLTAGE range pushbuttons.

The front panel TERMINALS consist of the following:

The two black VOLTAGE input terminals.

The three black CURRENT input terminals.

The single green CHASSIS connection.

The front panel OUTPUTS consist of the following:

The four digit DISPLAY.

The four indicator lamps.

NEGATIVE indicates that the POWER reading is negative.  
(Because of the TRUE RMS nature of the VOLTAGE and  
CURRENT readings these readings are always POSITIVE.)

OUTPUT OVERLOAD indicates that the output reading exceeds 1.5 times full scale hence the user should check that the operating controls are properly set. Readings MAY be VALID with this lamp lit.

INPUT OVERLOAD indicates that the peak input signal is about 1.5 times the RMS value of the range in use. Readings MAY be VALID when this lamp is lit.

The REAR panel of the instrument contains the following:

The line cord receptacle.

The 0.5 Ampere power input fuse.

The output opening for the IEEE-488 or BCD/REMOTE options.

The output for the ANALOG or the ENERGY option.

The input for the broad-band SHUNT option.

### 1-3. SPECIAL FEATURES

This section provides a brief introduction to several of the special features of the V-A-W Meter. This material should allow the user to avoid some apparent problems in their initial measurements with the meter.

#### POLARITY

First time users of TRUE RMS meters sometimes complain that the POLARITY indicator does not operate. The concept that must be remembered here is that true root mean square measurements involve squaring the input voltage or current and then taking the square root. Thus either plus or minus DC quantities will lead to positive outputs. The POLARITY indicator is only useful in the POWER case where power flow may be in either direction.

#### FLASHING DISPLAY

Another aspect of the TRUE RMS operation is that the dynamic range of the squared signals is much greater than the range of the input quantities. That is a 30/1 range of input voltage leads to an internal signal variation of 900/1. This means that with an applied signal of 1/30 th of the maximum input for a given range the internal signal - before the square root is taken - will only be (1/900)th as large as the maximum case. As one might expect this large dynamic range eventually leads to jitter at low inputs. For VOLTAGE and CURRENT readings below about 7% of the nominal full scale values the DISPLAY has been programmed to FLASH rather than to provide a steady reading as it does in all cases for POWER or POWER x10. This operation is normal it merely indicates that one has either no input or a small input and a CURRENT or VOLTAGE setting of the FUNCTION switch.

## DISPLAY READING WITH NO INPUT.

Both a CURRENT and a VOLTAGE pushbutton should always be depressed. With no button activated one of the input amplifiers is left with an open input and the DISPLAY reading may be both large and uncertain.

## POWER x 10 (Specified as to ACCURACY only for AC measurements.)

Since reducing the VOLTAGE and the CURRENT each by a factor of three reduces the POWER resulting from their product by a factor of nine the POWER x 10 function allows one to get reasonable power readings in these "down scale" conditions. Other than the 1000 V range all CURRENT and VOLTAGE inputs may be used up to 1.7 times their nominal full scale values. Whenever possible one should stay as far "up scale" as possible. Thus with a 240 V and a 700 mA combination of inputs one should use the 200 V and the 500 mA ranges together with the POWER function instead of the 1000 V and the 5 Ampere ranges together with the POWER x 10 ranges. However with a 70 volt input and a 150 mA input for a unity power factor case one would only get a 10.5 watt reading on POWER while on POWER x 10 the reading should be 10.50 watts. In general BOTH the VOLTAGE and the CURRENT should be at or below 40% of the nominal full scale value of a range before one uses the POWER X 10 function. With inputs having very high crest factors an even larger margin may be required.

## POWER FACTOR SETTING

The POWER FACTOR function on the V-A-W meter is to some extent a "gimmick". One can use the V-A-W meter to find the power factor in any single phase case by using it to measure the current, the voltage, and the power. Then by definition the power factor equals the power reading divided by the volt-ampere product. In the special case where BOTH the current and the voltage are sinusoidal the instrument can make this calculation and present a power factor reading directly. Even in this case there are both upper and lower limits on the amplitudes and frequencies of both the input current and voltage.

## CURRENT FUSE.

The three lowest CURRENT ranges are protected by a fast acting, 1.5 A fuse. If the three lowest current ranges do not operate while the 5 Ampere range and the VOLTAGE ranges do operate then this fuse may be blown and should be checked and, if necessary, replaced. On the Model 256 and those Model 255's that have the "Front Panel Fuse Option this fuse is located on the front panel. On other Model 255's it is located just behind the front panel on the Current Input Board. ( In this case the fuse is reached by removing the bottom cover of V-A-W Meter.

## 1-4. CONDENSED OPERATING INSTRUCTIONS - VOLTAGE AND/OR CURRENT

To make a VOLTAGE measurement:

- (a) Place the FUNCTION selector switch on VOLTAGE.
- (b) Connect the desired voltage between the VOLTAGE Common (LOW) terminal and the right hand VOLTAGE terminals.
- (c) Push in the appropriate one of the VOLTAGE RANGE selector buttons.
- (d) Read the DISPLAY.

NOTE: The left hand VOLTAGE (GREEN) terminal connects directly to the metal case of the V-A-W Meter.

### Hints and Precautions

Within the CREST FACTOR limitations the 20 V and 200 V ranges may be used up to 34 V and 340 V respectively. The 1000 V range inputs should be limited to 1000 V rms or 1500 V peak, whichever is smaller.

### CREST FACTOR

Except for the 1000 V range which is peak limited, the V-A-W Meter will measure pulse or "spike" inputs with peak values of at least 3.5 times the nominal full scale DC value. Peak to peak values around a zero average value may be up to seven times the nominal full scale value. Thus a 700 V peak should be handled without clipping on the 200 V range.

Voltages below 1/14 (nominal) of full scale are indicated by a flashing display. Lower values may be estimated, although some "jitter" is normal in these cases.

If high voltage, high frequency measurements are to be made, some reading "jitter" may occur. This "jitter"--if it occurs--can usually be removed either by grounding the VOLTAGE COMMON terminal or, if this is not possible, the by "floating" the instrument on a separate, external, low capacitance, isolation transformer and then tying the VOLTAGE COMMON terminal to the metal case of the instrument.

Since the V-A-W Meter is true RMS reading and indicating, it will read positively for either PLUS or MINUS dc inputs. Better accuracy for dc voltages may be obtained averaging the readings for PLUS and for MINUS inputs.

From the viewpoint of circuit loading, all voltage ranges "look like" 5 Mohms in parallel with 8 pF.

To make a CURRENT measurement:

- (a) Place the FUNCTION selector switch on CURRENT.
- (b) Open the LOW lead to the device or load that is to have its current measured. If either the "generator" or the "load" is grounded, one would normally connect the CURRENT COMMON terminal to the grounded side. Connect the other side of the opened lead to the appropriate one of the other two current terminals.
- (c) Push in the desired one of the CURRENT RANGE selector buttons. (Use the 5000 mA button with the 5 A max terminal and the other three buttons with the 0.5 A max terminal.)
- (d) Read the DISPLAY.

#### Hints and Precautions

Within the CREST FACTOR limitations the three lower ranges may be used up to 8.5, 85, and 850 mA respectively. The 5 A scale begin to have "drift" caused by self heating of the internal shunt if it is used for steady currents above 7.5 Amperes.

Currents below 1/14 (nominal) of full scale are indicated by a flashing display. Lower values may be estimated, although some "jitter" is normal in this case.

Since the V-A-W Meter is true RMS reading and indicating, it will read positively for either PLUS or MINUS dc inputs. Better accuracy for dc currents may be obtained by averaging the readings for PLUS and for MINUS inputs.

For the viewpoint of the circuit being measured the V-A-W Meter imposes a series impedance of about 20 ohms (5mA Range), 330 milliohm (500 mA Range), and 28 milliohms (5 A Range). At low frequencies this impedance is resistive. At high frequencies the input impedance of the three larger ranges may all contain a significant inductive component.

## 1-5. CONDENSED OPERATING INSTRUCTIONS - POWER

To make a POWER measurement one must first set the FUNCTION switch to POWER and then set up the instrument according to the instructions for BOTH voltage and current measurements. In making these connections several additional factors must be borne in mind.

There are two possible CONFIGURATIONS. If one defines a "generator" and a "load" then one configuration leads to a POSITIVE power reading and one to a NEGATIVE power reading. In addition to the SIGN of the reading the configurations differ in the "error" term that the meter loading introduces into the reading.

In the normal, or POSITIVE power configuration the high side of the generator is connected to the load. The load is returned to the generator via the current shunt of the instrument with the current COMMON terminal connected to the low side of the generator. The high voltage terminal is connected to the high side of the load. In this case the voltage reading is the sum of the load voltage and the voltage drop across the internal shunt of the V-A-W meter, thus the POWER reading is the load power plus the shunt power. Since the shunt current is just the current reading of the meter the shunt power is  $I^2r$ , where  $r$  is the shunt resistance for the particular scale in use. If the load resistance is 200 times or more than the shunt resistance then the error from this term will be less than 0.5%. The specification sheet lists the impedances of the various ranges.

The other configuration has the current connections to the instrument reversed. The argument for the use of this configuration is in certain low power factor cases where the correction factor matters and where the correction for this case which is  $(V^2/R)$ , where  $R$  is the voltage input resistance of 5 Mohms, is significantly smaller than the  $I^2r$  correction factor of the positive power configuration.

If one is measuring low loss, reactive components then the correction factor may be quite significant. By measuring the voltage drop across the current terminals at some convenient low frequency, with a sensitive ac voltmeter, an exact value may be calculated for the shunt resistance of a particular instrument and a particular range.

WHEN MAKING POWER CONNECTIONS ALWAYS INSURE THAT THE LOAD CURRENT FLOWS BOTH IN AND OUT OF THE CURRENT TERMINALS. DO NOT USE THE INTERNAL COMMON TO COMMON CONNECTION OF THE V-A-W METER TO CARRY HIGH FREQUENCY LOAD CURRENTS OR SIGNIFICANT ERRORS IN READINGS MAY RESULT.

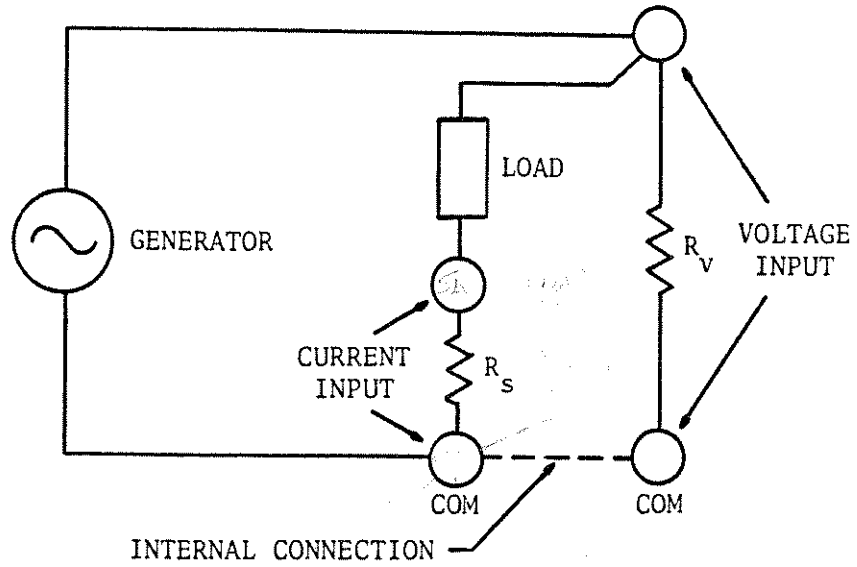

Shunt Low Wattmeter Connection. Meter Reading is Positive and Requires a Correction of  $I^2R_s$ .

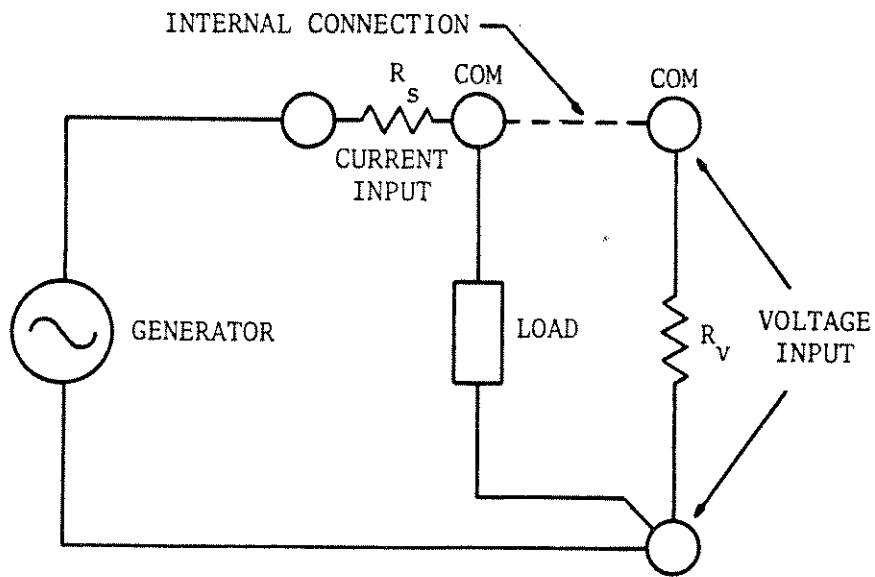

Shunt High Wattmeter Connection. Meter Reading is Negative and Requires a Correction of  $V^2/R_v$ .

### Hints and Precautions

When BOTH voltage and current readings are 1/3 of full scale, or less, then a x10 increase in resolution can be obtained by using the x 10 POWER setting on the FUNCTION switch. Decimal point adjustment is automatic.

When making high frequency, high power measurements one must take precautions to make sure that the quantities being measured do not enter the V-A-W meter by any means other than the input terminals. Methods of "illegal" entry may include the line cord, the cable used to connect to a BCD or REMOTE option, or a field between the metal case of the instrument and the COMmon terminals. Floating the instrument on an isolation transformer and tying the metal case to the COMmon terminals will prevent the case to COMmon field from existing. Tying the now isolated "white" wire of the line cord to the case, or the "green" wire of the line cord, may also be necessary in severe cases.

If a BCD option is installed then in some severe interference cases problems arise when the cable is connected to the rear connector. If internal shielding of the connecting cable is not sufficient then it may be necessary to mount the BCD card external to the instrument and run the ribbon connector from the card's isolators through the rear panel opening.

### 1-6. CONDENSED OPERATING INSTRUCTIONS - POWER FACTOR

One normally makes a direct Power Factor (sinusoidal-like waveshapes only) measurement with the same configuration used in measuring POWER. Only the FUNCTION switch changes position. THE POWER FACTOR FUNCTION IS ONLY VALID FOR SINUSOIDAL LIKE INPUTS FOR BOTH CURRENT AND VOLTAGE. When either waveshape is non-sinusoidal then the true POWER FACTOR may always be obtained by dividing the POWER reading by the product of the CURRENT and the VOLTAGE readings.

#### Hints and Precautions(Power Factor)

Both the current and voltage readings individually must be less than 1.7 times full scale. The input volt-ampere product must be greater than 1/3rd and not more than three times the full scale value of the resultant power setting. Operating frequency should be 30 kHz or less.

With NO input the Power Factor reading is NOT zero but may be large (in the neighborhood of 8.000) and jittery. (The Power Factor reading requires that the circuit perform a division operation. With no input this leads to a division by zero and hence to a large output that causes an OUTPUT OVERLOAD indication and a meaningless reading.)



## 1-7 THREE PHASE POWER MEASUREMENTS

Three phase power transmission systems exist in both three wire and four wire versions. To measure the power in a "N" wire system one must measure the currents in at least  $(N - 1)$  of the wires and one must measure at least  $(N-1)$  appropriate voltages.

One can define a single phase wattmeter as a device that senses one line current and multiplies it by an appropriate voltage to produce a power reading. Two properly connected single phase wattmeters will always be sufficient to measure the power in a three wire, three phase system and three properly connected single phase wattmeters will always be sufficient to measure the power in any three phase system of either three or four wires.

If one is dealing with "normal" line frequencies of from 50-500 Hertz and with line currents of up to 7.5 Amperes RMS then one can use any of the Clarke-Hess Models 255, 256, or 259 as the single phase wattmeter defined above. The connections for both the two wattmeter/three wire case and for the three wattmeter case are shown on the next page.

In either case note that only three connections are necessary to each wattmeter. For normal line frequencies one should not encounter any difficulties in "floating" the internal circuitry of any Clarke-Hess wattmeter at voltages up to 480 V above the normal earth ground.

In either case the total power is the ALGEBRAIC SUM of all the wattmeter readings. In the three wattmeter case a balanced load and balanced input voltages should lead to three equal power readings. In fact if one could guarantee that the load would always be balanced and that the input lines were equal then only one wattmeter would be necessary. In that case the total power would just be three times the reading of the single wattmeter. In the two wattmeter case the two wattmeter readings are only equal in both magnitude and sign for the very special case of a balanced and unity power factor load. For low power factor loads the readings will be opposite in sign so that the net result may be smaller in magnitude than either reading. For very low power factor load cases one might be better off with three wattmeters so as to avoid the errors that might result from obtaining an answer as the difference of two almost equal numbers.

The necessary meter summation may be done by the operator or by a computer if the various wattmeters are each equipped with either an isolated IEEE-488 bus or with an isolated BCD readout. For the two wattmeter case Clarke-Hess has an option that provides for the isolated interconnection of the digital portion of the two instruments so that when the "master" unit has a front panel toggle switch placed in the "three phase" position then that instrument displays the algebraic sum of what would be the power readings of the two individual instruments.

For currents above 7.5 amperes one must use either external shunts, current transformers, or Hall effect transducers to extend the current range of the instruments. The easiest extensions are to convert the 50 mA range into a 50 Ampere range or the 500 mA range into a 500 Ampere range. In either case the power readings are correct as long as they are called kilowatts instead of watts.

For higher frequency three phase measurements the use of three wattmeters and broad band current transformers provides current isolation that allows one to tie the three voltage common terminals both together and to the chassis ground. Broadband current transformers can be provided for currents from 500 mA or more. In this special case the HIGH voltage terminals are connected to the high voltage lines while the COMMON voltage terminals are tied together and the current transformers are connected so that positive power readings are obtained into a resistive load. The advantage of being able to tie the COMMON terminals to the chassis ground is that it prevents high frequency pickup between a "floating" COMMON and the grounded metal case.

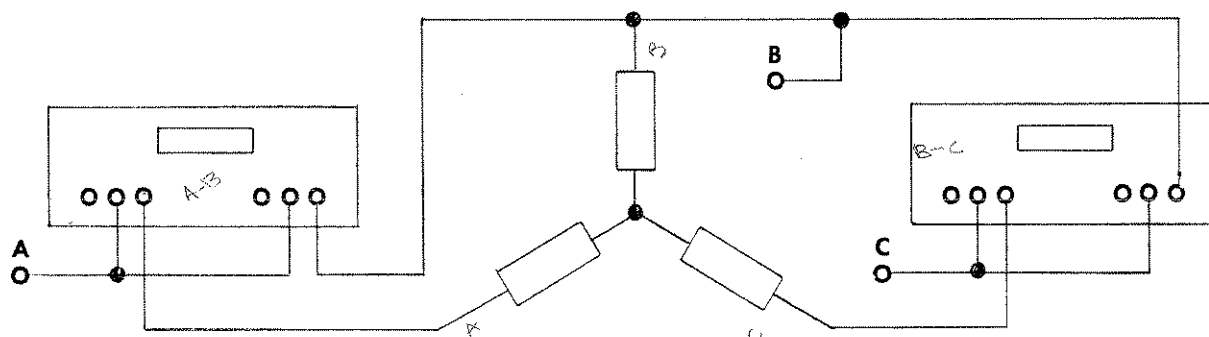

Two Wattmeter/Three Wire Case. (delta or Y Load)

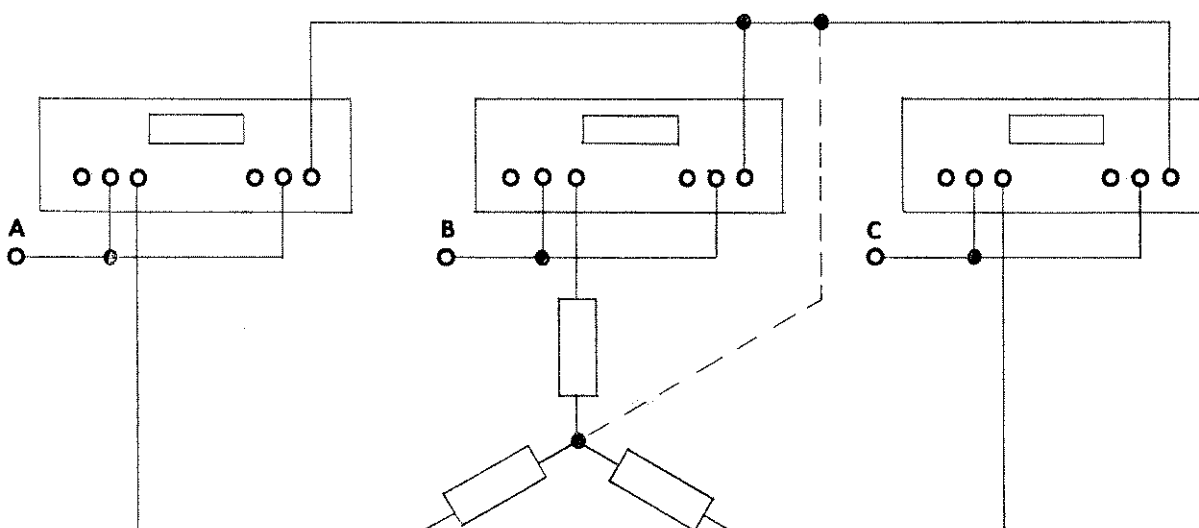

Three Wattmeter/Three or Four Wire Case.

## II. CALIBRATION: MEASUREMENT AND ADJUSTMENT

This chapter is devoted to the checking of the calibration of the V-A-W Meter and, if necessary, to the adjustment of the calibration. The EVEN numbered sections of the chapter may be followed if a CALIBRATION CHECK is required. The ODD numbered paragraphs include details on the readjustment procedure.

### 2-1. CALIBRATION EQUIPMENT AND STANDARDS

To outline the procedure necessary to check the calibration is quite straightforward. To perform these checks introduces the traditional calibration problem of having a standard of comparison. At low frequencies, or dc, voltage and/or current standards are fairly common. At high frequencies, and/or high voltages, and/or high currents they are both less common and, in general, require much more care in their proper application.

The V-A-W Meter is a broadband, true RMS reading instrument with capabilities of measuring large currents and voltages. The frequency response of the V-A-W Meter is several orders of magnitude greater than that of the traditional, averaging responding, AC digital voltmeter. Therefore, while comparison with such meters may be quite valid from dc to 1-2 kilohertz, it may be complete nonsense for non-sinusoidal waveshapes or for frequencies above several kilohertz.

To check the accuracy of the V-A-W Meter AT A SPECIFIC FREQUENCY and with A SPECIFIC WAVESHAPe requires an independent means of determining the WAVESHAPe, and the AMPLITUDE of the input signal. To check the FREQUENCY RESPONSE requires that either the generator WAVESHAPe and AMPLITUDE be known to be frequency independent or that a FREQUENCY INDEPENDENT means of verifying the waveshapes and amplitude be available.

Calibrators such as the FLUKE 5100 B series will produce currents from DC to 5 kHz and voltages up to 19.9999 V from DC to 50 kHz. By combining such a voltage source with a 4,000 ohm metal film resistor (such a resistor is nearly frequency independent in this frequency region) one may obtain currents of 5 mA up to 50 Khz. For higher frequencies a high quality commercial function generator will provide a reasonable source of constant amplitude, constant waveshape signals. When their usage is restricted to frequencies of less than 1/2 of the maximum rated output, and in particular if one stays on one frequency range, then such generators will produce a sine wave response that is flat to within  $\pm 0.3\%$  over a frequency range of 20/1 or more.

For broadband current calibrations Clare-Hess employs their own "in house" calibrator that is capable of providing constant currents of up to 5 Amperes from 50 Hz to 500 kHz and lower currents up to 750 kHz.

## 2-2. CALIBRATION MEASUREMENT - ZERO

The V-A-W Meter "zero" must be checked on the FOUR different FUNCTIONS of CURRENT, VOLTAGE, POWER and POWER x10. \*\*

### Power and Power x10

Between these two functions there are 24 possible current and voltage combinations. Ideally the ZERO reading should be ± 000 (the left hand zero is blanked) for all 24. Allow the instrument to warm up in the case for at least 15 minutes before making this measurement.

In interpreting a departure from ± 000 one should bear in mind that some voltage-current combinations produce FULL SCALE values of 1000 and some combinations produce FULL SCALE values of 5000, or have FIVE times the gain with respect to zero drift.

The magnitude of the ZERO reading should be no more than 0.1% (1/1000) of the FULL SCALE value. That is, with a 1000 digit FULL SCALE value the ZERO reading should be -001, -000, 000, or 001. (Minus is indicated by the NEGATIVE light emitting diode.)

If the reading is outside these limits note whether the "poor" reading is associated with a particular current or voltage range.

Before making ANY adjustments proceed to the Voltage and Current ZERO measurement outlined below.

### Voltage and Current

Since the V-A-W Meter reads the TRUE ROOT MEAN SQUARE value of a VOLTAGE or of a CURRENT the result is ALWAYS POSITIVE. It is a further characteristic of TRUE RMS reading instruments that for values near zero the effective "gain" is very high. (Analog TRUE RMS meters traditionally set the bottom readings of a scale to 1/3 of the full scale value. This means that on such a meter readings below 1/3 of full scale require one to change ranges.)

---

\*\* With no input the POWER FACTOR setting produces a meaningless reading. This reading often consists of a flashing display coupled with the lighting of the OUTPUT OVERLOAD lamp. This situation is normal. The POWER FACTOR calculation involves the division of the measured POWER term by the measured VOLT-AMPERES term. With no input this ratio is indeterminate.

Because of the "high gain" phenomena the readings near zero are "noisy" or "jittery". In the V-A-W Meter VOLTAGE and CURRENT inputs of less than 1/15 of FULL SCALE cause the display to flash. This flashing warns the user that the data is suspect while still allowing him to use it as an indicator. Since valid negative readings are not possible, the circuitry has been arranged to reduce the "gain" for readings in the negative direction. This means that, with regard to zero readings on the voltage or current ranges, the V-A-W Meter is highly non-symmetrical.

The ideal zero setting would be -000 for all current and voltage settings. An acceptable range of zero settings are those that lie between -0.1% of FULL SCALE and +1.0% of FULL SCALE. (Since the positive readings both flash and jitter, the most pleasing zero value is -000.) Thus for any CURRENT range the ZERO reading should lie between -005 and +050 (with jitter) with an ideal value of -001 or -000.

### 2-3. CALIBRATION ADJUSTMENT - ZERO

Assuming that no parts changes nor major adjustments have been made the ZERO may be "set" by adjusting the AUTO ZERO input control, P49 (near the rear of the main board in the second "column" from the left). Normally if this control is adjusted on CURRENT the setting will be satisfactory for all the other FUNCTIONS. If parts changes have been necessary then the zero adjustment will form part of the "set-up" procedure covered in Chapter IV on troubleshooting and repair. The "zero" setting will have a large effect on VOLTAGE or CURRENT readings near the bottom of each range.

If there is either a large zero offset on all FUNCTIONS or on a particular FUNCTION or RANGE, there is apt to be a more serious problem that will again require reference to Chapter IV.

Read Section 2-5 before making any ZERO adjustment.

### 2-4 CALIBRATION MEASUREMENT - CURRENT

The calibration measurements for current or voltage can be done in either order. If calibration adjustments are necessary then the CURRENT adjustment should be done FIRST.

There are essentially two "cross-sections" that are reasonable to take through the set of all possible current measurements.

- (a) For a given waveshape--normally sinusoidal--one can check each of the four ranges at or near 1/10 FULL SCALE, FULL SCALE, and 1.7 FULL SCALE. Assuming that the waveshape is sinusoidal and that the frequency is between 30Hz and 100kHz then each reading should be within 30 digits ( $\pm 0.4\%$  of Full Scale)  $\pm 0.2\%$  of the Reading.

If all the FULL SCALE values are HIGH or all are LOW then a Calibration Adjustment is possible. If all the 1/10 FULL SCALE values are HIGH or all are LOW then another Calibration Adjustment is possible. If some ranges are correct and others are not and IF THE CALIBRATION EQUIPMENT IS VERIFIED AS WORKING CORRECTLY then one should check the CURRENT ATTENUATOR section of Chapter IV.

If only a single CURRENT range is of primary interest then the calibration check might be restricted to that range.

- (b) For a given RANGE, a given WAVESHAPE--normally sinusoidal, and a given AMPLITUDE--normally in the vicinity of FULL SCALE--one can check the FREQUENCY RESPONSE.

For values near FULL SCALE the response should remain within the specified limits of  $\pm 50$  digits from 10 to 30Hz, from  $\pm 30$  digits from 30Hz to 100kHz, and within  $\pm 60$  digits from 100 to 300 kHz.

Reference to the SPECIFICATIONS and its accompanying "Notes" will be helpful in interpreting the resultant readings. At the low frequency end of the measurement the frequency at which the display begins to "track" the instantaneous value of the input signal will depend upon the internal filter configuration.

If DC readings are desired then they should remain within the specified accuracy limits. The average of the display value for positive and for negative DC inputs ( both readings will be positive because of the RMS action ) should lie within the increased accuracy specified for the 30Hz to 100kHz region.

The variation of the response of the V-A-W Meter to variations in frequency is "smooth"; hence only the limiting values and several central values of frequency should suffice to indicate whether a given range is within its frequency specifications.

The 5mA range has a frequency adjustment that should be made BEFORE any other current range has a frequency adjustment performed. Each of the other ranges has a separate control. The details for each range are discussed in the appropriate portion of Section 2-5.

## 2-5. CALIBRATION ADJUSTMENT - CURRENT

- (a) All ranges in error.

The low frequency current calibration adjustments consist of three steps. To some extent these steps are interactive.

Before making any of these adjustments, make sure that they are really necessary!

Before making any of these calibration adjustments check that the dc and ac readings called for in Sections 4-6-1, 4-6-2, and 4-6-3 are present. If not, make the necessary adjustments first

The three calibration adjustments for CURRENT are:

- (1) ZERO - Adjust P49
- (2) 1/10 Full Scale - Adjust P74
- (3) Full Scale - Adjust P66 (or P58)

The current calibration can be made on any convenient scale. (When the four current scales are compared on a relative basis, they should agree within  $\pm 0.1\%$  (normally within  $\pm 0.05\%$ .) For best accuracy one might consider the position of the calibrated scale within this "spread".

For purposes of illustration, we assume that the calibration is done on the 5mA scale.

- (a) With a 200.0 microamp input (1/25th of full scale) adjust P49 (Zero Control) for a reading of  $.200 \pm$ . (This reading will "flash" and "jitter". Adjust for an "average" reading of 200 digits.) Since the low end of the true RMS scale is extremely sensitive to the "zero" setting, it is more rational to set the "ZERO" this way rather than adjusting it to read .000.
- (b) With a 500.0 microamp input (1/10 of full scale) adjust P74 for an average reading of .500. If adjustment should not be possible, R73 will have to be moved from position 73A to position 73B (or vice versa). Check item(c) first.
- (c) With a 5.000mA input (full scale) adjust P66 (or P58) for a reading of 5.000mA. If IC7 has been replaced and as a result a large change is necessary in the full scale setting, then the (b) adjustment should be rechecked.

ALLOW TIME for the READING to "SETTLE" before READJUSTING

After these adjustments, one should check the reading at 8.500mA (1.7 times full scale). The deviation from the "correct" value should typically be less than  $\pm 12$  digits (.15% of the reading). The specifications would allow a deviation of 0.4% of full scale or 20 digits plus 0.2% of the reading or 17 digits, for a total deviation of  $\pm 37$  digits. The typical error at this point is less than 1/4 of the total allowable error.

If the CURRENT calibration is readjusted then both the VOLTAGE and then the POWER calibrations must be rechecked and if necessary readjusted.

(b) One range in error.

If only one current range is in error, then the problem is either on the Current Input board or with the Current Range Switches. There are no relative range adjustments. Consult the factory for advice.

(c) Frequency adjustments

Each current range has a control for frequency adjustment.

Before touching these adjustments, make sure that you have a calibration source whose "flatness" is known up to at least 300kHz to at least 0.05%.

5mA Frequency Response

C51 adjusts the response for all four current ranges. If an IC1 should have to be replaced, then this trimmer might require readjustment. (If several pieces of a 3130 are available, one might try them in the IC1 socket to see which required the least adjustment.) After the DC adjustments required by the change of the IC have been made then adjust the source for a convenient reading at 1kHz; then go to 300kHz and note the reading for the SAME input. It should be possible to adjust C51 so that the reading is within  $\pm .3\%$  of the reading. The "best" adjustment requires "sweeping" across the band. Up to 100kHz it is desirable that the reading should be within  $\pm 0.1\%$  of the reading at 1 kHz.

After the 5mA response has been adjusted then the other three ranges can be adjusted.

50mA Frequency Response

Check the 5mA response BEFORE making the 50mA adjustment. The actual adjustment is made with P119 behind the 500 mA push button switch).

The "best" adjustment is made as in the 5mA case.



### 500mA Frequency Response

Check the 5mA response BEFORE making the 500mA adjustment. The actual adjustment is made with P115 (located on the inside end of the Current Input Board). The same criteria hold for the best adjustment as were applicable in the 5 mA case. The bottom must be on when checking this adjustment.

### 5A Frequency Response

Check the 5mA response BEFORE making the 5A adjustment. The actual adjustment is made with P114 (located on the outside end of the Current Board). External current loops will influence this adjustment. Attempt to place the wires as they will be in the final measurement case. Minimize external loops. Note that 5 Ampere scale is only specified to 200kHz.

## 2-6. CALIBRATION MEASUREMENT - VOLTAGE

The calibration measurements for VOLTAGE are similar to those for CURRENT with the following exceptions.

(a) Since the FULL SCALE values for VOLTAGE are either 2000 or 1000 digits, the allowable digits of error are smaller although the percentage errors are identical.

(b) If a voltage source is available that allows one to run the 1000 V range at high frequencies (say above 5kHz) it may be desirable to "float" the V-A-W Meter on an isolation transformer and then to tie the VOLTAGE COMMON terminal to the metal case of the V-A-W Meter. This will prevent (or greatly reduce) potential high frequency leakage paths that might cause "jitter" on high voltage/high frequency readings. Further reductions of such jitter may sometimes be accomplished by tying the low side of the isolated line cord to the metal case of the instrument. Whether such precautions are necessary depends to a large extent upon the output circuitry of the voltage source employed. If the VOLTAGE COMMON terminal is "close" to "ground" then "jitter" will be unlikely to occur.

## 2-7. CALIBRATION ADJUSTMENT - VOLTAGE

Normally the controls associated with the square root circuitry (P66 and P74) are adjusted with a CURRENT input and left untouched for the VOLTAGE case.

- (a) All ranges have FULL SCALE high or low.

P1, the VOLTAGE channel gain control, adjusts all three VOLTAGE ranges at the same time.

- (b) The 20 V range is correct at FULL SCALE and the 200 V or 1000 V range is high or low.

P140 (200 V) and P138 (1000 V) located inside the VOLTAGE ATTENUATOR BOX provide individual controls for these two ranges, assuming that the 20 V range is correct.

- (c) One or more ranges has a frequency response error.

C133 (located inside the VOLTAGE ATTENUATOR BOX) provides frequency compensation adjustments. C133 should be turned on the 20 V range. Final adjustments should be made with the BOX lid in place and then checked with the instrument bottom cover in place. Since the 200 V and 1000 V outputs are very low impedance, a single frequency adjustment on the 20V range adjusts the response for all three ranges.

## 2-8. CALIBRATION MEASUREMENT - POWER

There are basically two approaches to the measurement of the calibration of the POWER scales.

- (a) If an adequately calibrated WATTMETER is available then a direct comparison of the POWER scale is possible.

In making this comparison the configuration data and "error" terms outlined under Section 1-3 on POWER Measurement should be reviewed. For accurate calibration checks  $I^2R$  or  $V^2/R$  corrections should be applied to the V-A-W Meter readings.

- (B) If a calibrated WATTMETER is not available then one uses a RESISTIVE LOAD and a known WAVESHAPE, usually a sinusoid, and calculates the POWER as the product of VOLTAGE and CURRENT. This approach also verifies the fact that the different FUNCTIONS of the instrument provide consistent readings. If external voltmeters or ammeters are used, the  $I^2R$  or  $V^2/R$  correction--depending upon the configuration employed--should be applied. If the V-A-W Meter I and V readings are used, then  $P = VI$ .

The allowable error in digits is calculated from the SPECIFICATIONS and from the FULL SCALE combination of VOLTAGE and CURRENT.

No matter whether one uses a calibrated WATTMETER or the VI product to measure the POWER, one still has the problem of determining the frequency response for both resistive and non-resistive loads.

#### Frequency Response - Unity Power Factor

The variation of the POWER reading with frequency is approximately the sum of the variation of the VOLTAGE channel and the variation in the CURRENT channel (being used for the particular power measurement). Thus if both the CURRENT and the VOLTAGE channels fall off by 0.2% at a certain frequency then the POWER reading (assuming a purely resistive load) may fall off by 0.4%.

#### Frequency Response - Non-Unity Power Factor

If the Power Factor of the LOAD is accurately known--for example, a low loss (high Q) capacitor will have a Power Factor near zero --then the POWER reading can be calculated (for a sinusoidal (input) as  $VI \cos \theta$  where V and I are the RMS values of the VOLTAGE and CURRENT and  $\theta$  is the angle between them or  $\cos \theta$  is the Power Factor of the LOAD.

It is generally difficult to "sweep" out the frequency response in the reactive load case since for a given load the current and/or the voltage also varies with frequency. The best that one can do in most cases is to make measurements at certain specific frequencies.

The appropriate  $I^2R$  or  $V^2/R$  correction may make up 99% of the actual reading in the case of a truly very low loss or nearly zero power factor load.

### 2-9. CALIBRATION ADJUSTMENTS - POWER

#### Unity Power Factor Case

The FULL SCALE reading in the unity power factor case may be adjusted with P58 (which will also vary the readings on VOLTAGE and CURRENT) or with P84, which will vary only the POWER reading.

In making the POWER adjustment one must be careful to make the proper comparison between what the V-A-W Meter is measuring and what the comparison instrument is measuring. For example if the normal configurations is used with a resistive load then the V-A-W Meter measures the IV drop in the load plus the  $I^2r$  drop in the internal current shunt. If an external current meter is used to monitor I then the drop across this meter must be included in calculation. If the POWER setting is made in comparison with the V-A-W Meter's CURRENT and VOLTAGE settings then there are NO corrections necessary.

### Non Unity Power Factor Case

There are no separate phase adjustments for the non-unity power factor case. The phase and amplitude adjustments for the current and voltage channels individually must be adjusted so that the volt-ampere product produces a "zero" output when the two inputs are 90 out of phase. In general such adjustments should not be required. If you feel that they are, consultation with the factory is advisable before they are undertaken. (C31, C39, C117 etc. are phase "trimming" capacitors.)

#### 2-10. CALIBRATION MEASUREMENT - POWER FACTOR

THE DIRECT READING POWER FACTOR FUNCTION IS ONLY VALID WHEN BOTH THE VOLTAGE AND THE CURRENT ARE SINUSOIDAL. POWER FACTOR FOR OTHER CASE MAY ALWAYS BE DETERMINED AS THE POWER READING DIVIDED BY THE VOLT AMPERE PRODUCT.

With a SINUSOIDAL input--within the limits set forth in the SPECIFICATIONS--the POWER FACTOR should read  $1.00 \pm$  or between 0.97 and 1.03 for a resistive load and between  $\pm 0.03$  for a purely reactive load and a frequency that leads to a FULL SCALE combination of VOLT-AMPERES. The appropriate  $I^2R$  or  $V^2/R$  correction must be made if one wishes to compare the calculated POWER FACTOR from the appropriate VOLTAGE, CURRENT, and POWER measurements with the measured POWER FACTOR value.

#### 2-11. CALIBRATION ADJUSTMENTS - POWER FACTOR

P61 allows one to adjust the FULL SCALE, UNITY POWER FACTOR load case to a reading of 1.00. P63 allows offset corrections should IC21 require replacement.

To calibrate the POWER FACTOR range one needs a variable sinusoidal source and a resistive load. Ideally with a Full Scale voltage one wants to achieve approximately a Full Scale current. As an example (20 V, 5mA, 100mW) With a source variable from 10 to 30 V then a 4,000 ohm resistor (or any stable resistor from 3,800 to 4,200 ohms) would provide roughly a 5mA reading with a 20 V input. This combination will allow one to vary the POWER from 25mW at 10 V to 300mW at 34.6 V.

Adjust P63 so that the POWER FACTOR reading does not vary more than  $\pm 3\%$  over this range. Adjust P61 so that the reading near 100mW (i.e, nominal Full Scale) is slightly less than 1.000, say .995. Usually one goes back and forth between a P63 adjustment at 30 mW and a P61 adjustment at 100 mW. Normally the reading "bows" upwards at both the low and the high extremes of the power.

### III. THEORY OF OPERATION

Geographically the V-A-W Meter is broken into four printed circuit boards plus its front and rear panel controls and terminals.

Electrically the main printed circuit board may be thought of as being broken down into an ANALOG section, a DIGITAL section, and a POWER SUPPLY section.

The three smaller printed circuit boards include the DISPLAY/Counter & Latch board, which plugs into the main board; the CURRENT ATTENUATOR board, that is mounted on the current input terminals; and the VOLTAGE INPUT board, which is mounted inside the bottom mounted voltage attenuator box.

The diagrams chapter (VI) of the Instruction Manual contains separate schematic diagrams for all five of the boards or sections capitalized above.

Figure 3-1 illustrates this breakdown of the instrument.

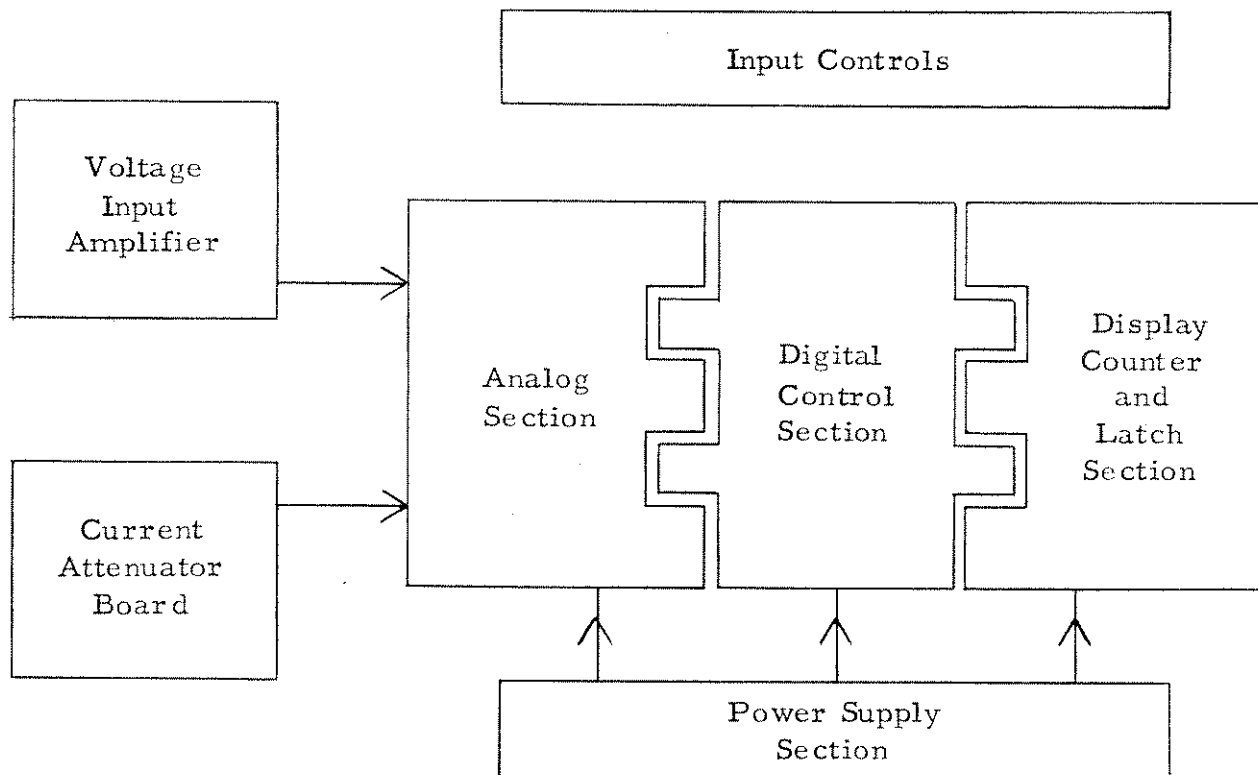

### 3-0. GENERAL OPERATION

The signals to be measured enter the V-A-W Meter via the Voltage and/or Current Input Terminals. The Voltage signals are attenuated, frequency compensated, and converted to an impedance level of less than 100 ohms before being sent on to the Voltage Amplifier portion of the Analog Section of the MAIN printed circuit board. This action takes place in the Voltage Attenuator Box.

The Current signals are converted to voltages (nominal values of 100mV RMS for Full Scale sine waves) on the Current Attenuator Board. Frequency compensation for the two lower current ranges is located on the MAIN board while the compensation for the 500 mA and 5 ampere ranges is located on the Current Attenuator Board.

The Analog Section contains Current and Voltage Amplifiers (two stages each), the CMOS switches necessary to "steer" the input signals along the proper paths, the Input Overload Detectors and Multiplier, the Auto Zero circuitry, the Power Factor Detector, the Square Root Drive Circuitry, and the Integrator/Comparator part of the A/D converter.

The Digital Section contains the decoding and logic circuitry necessary to translate the Function and Range Switch commands into Decimal Point and Full Scale settings and into the necessary control signals to operate the instrument. This section also contains the High and Low Frequency Clock generation circuitry, the Output Overrange and the Input I/V Under-Range circuitry, the Polarity determining circuitry, and the Drivers for the various electronic switches. Most of the Digital logic circuitry is of the CMOS type.

The Display/Counter/Latch board contains the four digit LED output display, the four LED signal lamps, the Counter portion of the A/D converter, the BCD latches that "hold" the output display values for operating remote printers or computers, and various auxiliary control and driver circuitry.

#### 3-1. CURRENT ATTENUATOR BOARD

The Current Attenuator Board is located directly behind the current input terminals. It is reached by removing the bottom half of the V-A-W Meter case.

The board contains the four current shunts that provide the input current/voltage conversion for the instrument. In addition this board contains an input fuse that offers protection on the three lowest current ranges, as well as frequency compensation and additional protection

components. The shunts are adjusted at the factory and should not require further attention by the user. This board is made up completely of passive components. The board operates in conjunction with the Current Range Push Button Switches to supply a nominal value 100mV RMS to the input of IC1 (on the MAIN board) when a Full Scale current is applied to any range.

### 3-2. VOLTAGE ATTENUATOR BOARD AND BOX

The Voltage Attenuator Board is located inside the VOLTAGE ATTENUATOR BOX which is in turn located just behind the Voltage Input Terminals.

The voltage box contains the input high impedance voltage attenuator, a unity gain buffer amplifier, and the low impedance 200 V and 1000 V range calibration attenuators. The five meg-ohm input attenuator is frequency compensated by adjusting C133. The attenuator output passes through a unity gain amplifier to the 200 V attenuator (P140, R140, and R141) and the 1000 V attenuator ( P138, R138, and R139).

The unity gain, FET input, low output impedance, amplifier (Q130, 131, 132, 133, and 134) has its own auto-zero circuit controlled by three CMOS switches contained in IC131 (CD4016) These switches are driven by a level shifted, and somewhat time shortened versions of the LL and NOT LL pulses. IC132(CD4054) is the non-inverting level shifter that drives the CMOS switches. C138 provides the voltage storage element for the auto-zero loop. P130 provides a small adjustment for the DC offset from the amplifier.

A full scale input on any voltage range should cause about a 60 mV output to the input of the second stage. (TP 1 on the main board) Excessive input capacitance of some meters and their leads may cause circuit oscillation and prevent a direct measurement at this point. If so then make the measurement at the output of IC2 (CA3130) where the nominal reading is 350 mV.

### 3-3. DISPLAY BOARD

The Display Board contains the visual and electrical outputs from the V-A-W Meter. In addition it contains the instrument's counting circuitry. This circuitry provides the timing necessary for various "control" functions within the rest of the instrument as well as the timing necessary for the A/D conversion of the DC output from the Analog Section of the Meter.

The Display Board also houses a set of Binary Coded Decimal (BCD) latches that hold the electrical equivalent of the number displayed by each LED digit. This number is updated with the display (normally at a rate of 10/second for 60 Hz operation and 8.33/second for 50 Hz operation.) The Load Latch (LL) pulse from the Digital Section controls the latch updating. Since the LL pulse is nominally about 80 usec wide the latch data is valid for over 99.9 out of every 100 milliseconds. A HOLD terminal is available that allows present value of the latched data to be held for as long as desired.

The Display Board communicates with the rest of the instrument through a 16 pin connector, J 1. If the BCD latch data is required elsewhere it is available at two 14 pin sets of holes located near the top of the board. These holes would normally be connected to an isolated option (BCD or IEEE-488) via a set of ribbon cables.

Incoming information supplied to the Display board includes the Decimal Point settings, the drive signals for the four indicator lamps, the LL pulse, the High frequency Clock signal, and two control signals known as ACTIVE and NOT SIGNAL. The two signals that leave this board and return to the MAIN board are a negative going step that occurs every 900 counts (the 900 pulse) and a positive going pulse (100 nsec to the 10% point) that occurs every 999-1/2 counts. The negative going pulse lasts from 900 to 999-1/2 counts. Since the clock that reaches this board and is counted has rates of 100kHz, 200kHz, or 500kHz (depending upon the portion of the control cycle and on the Full Scale setting of the Meter), this pulse width has three possible correct widths. Their relationship will become clear when the Digital Section is discussed.

All of the circuitry on the DISPLAY BOARD operates from the regulated +5 V power source.

### 3-4-0. ANALOG SECTION - GENERAL

The Analog Section of the V-A-W Meter may be broken into several subsections. The first of these contains the two stage input amplifiers, the multiplier, and the multiplier output circuitry. This section is controlled by ten CMOS switches shown in figure 3-2. The first subsection consists of IC1-4, 7, 11-13; Q3-9; and the adjustable controls P1, 2, 12, 20, 28, 44 and 49.

The output of the first subsection is applied to the analog portion of the A/D converter. This connection, as well as the control network for the rest of the Analog Section, is made by the appropriate closure of the nineteen CMOS switches shown in Figure 3-3. IC±s 30 and 31 comprise the center of this subsection.

The Reference voltages for the A/D conversion are generated either by the P84/IC20 combination or by the Q16, Q17, P66, P74 combination.

The other half of the IC20, together with Q14 and Q15, and P49 make up the Auto Zero circuitry.

The drive signals for the various switches are listed in Table 3-1. The timing for many of these signals is illustrated in Figure 3-4. The discussion of the generation of the control signals is largely in Section 3-5 on Clocks and Timing.

The last subsection of the Analog circuitry consists of the Input Overload Detectors.



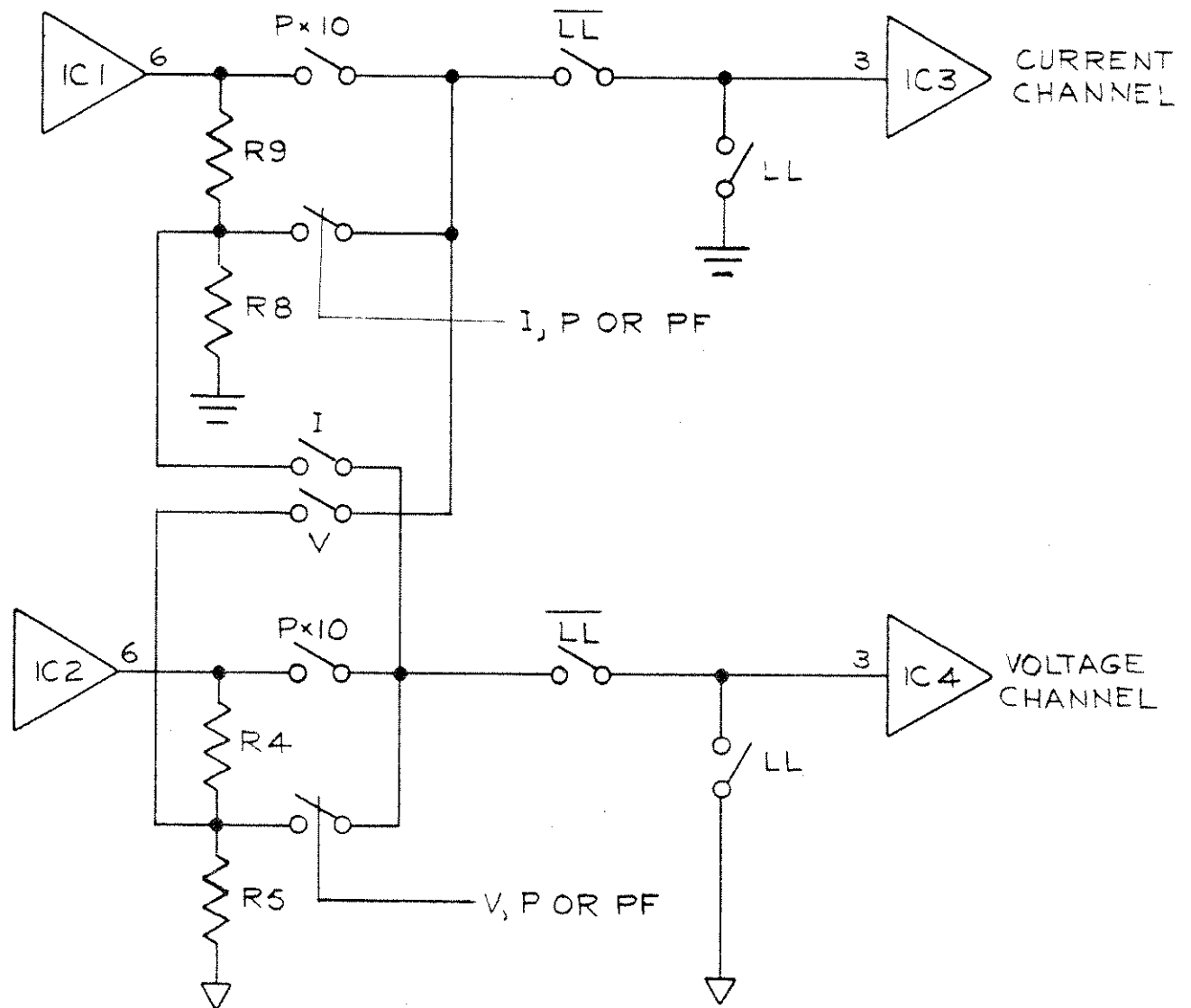

Figure 3-2. Front End CMOS Switching. Switches are closed when indicated drive signals are present, and open otherwise.

### 3-4-1 AMPLIFIER / MULTIPLIER / INPUT CMOS SWITCHES

The analog signals from the two input boards are amplified in IC1 (Current) and IC2 (Voltage). These are wideband, high input impedance, negative feedback amplifiers with nominal gains of 3.5.

Each amplifier has a dc offset control that is used to adjust its output to zero volts. In addition the voltage channel has a relative gain control, P1, that allows the voltage and current channel gains to be matched exactly.

The second stage of each amplifier channel consists of a similar wideband amplifier with a voltage gain equal to 4.3. Except in the POWER x 10 case, the output of each of the first stages is attenuated by 0.31623 hence the net gain from the first amplifier to the multiplier is normally 1.36. In the POWER x10 case this 0.31623 attenuator is switched out so that the gain of the PRODUCT of the two channels is increased TEN times.

The four CMOS switches driven by the LL and th NOT LL signals are part of the AUTO-ZERO loop. The LL pulse is approximately 80 usec wide and occurs after the end of the A/D conversion. During this period the inputs of the second stages are grounded while the outputs of the first stages are open circuited. Thus the first stages are outside of the AUTO-ZERO loop while the second stages and the multiplier (IC7) are included in it.

The multiplier (IC7) receives the two analog signal inputs together with control inputs from P20, 28, 44 and 46, and produces an instantaneous product of the inputs. After processing by the output circuitry (Q4-Q9), the low frequency (near dc) portion of this product is separated out by the output filter (R56, 57, C23, 24) and used as one input to the A/D converter. The multiplier output is connected to the filter via switch S4. This switch is closed except during the AUTO-ZERO interval.

### 3-4-2. AUTO-ZERO CIRCUITRY (AMPLIFIER/MULTIPLIER)

During the 80 usec LL interval S13 and S15 close while S4 and S14 open. In addition the inputs to the two second stage amplifiers are grounded while the signals driving these amplifiers are removed (IC11 and 12). The result is that the 5, 6, 7 portion of IC20 serves as a high gain amplifier in a feedback loop including itself as well as Q14 and Q15. This loop forces C21 to charge until the resultant current from Q15 combines with the net multiplier output current to cause the negative input to IC20 (Pin 6) to equal the positive input to IC20 (Pin 5). Since the Pin 5 voltage is set by the ZERO adjustment, P49, this current balance sets the output zero. (R58 provides a constant dc offset current for Q15 to insure that it is always turned on.) Once the LL period is over, S15 and S13 open but C21 retains its voltage; hence the zero balancing current continues to flow from Q15's collector. This means that any dc drifts--in the second stage amplifiers, the multiplier, or the multiplier output circuitry--that are slow compared to the period (100 msec) between LL pulses will be removed.

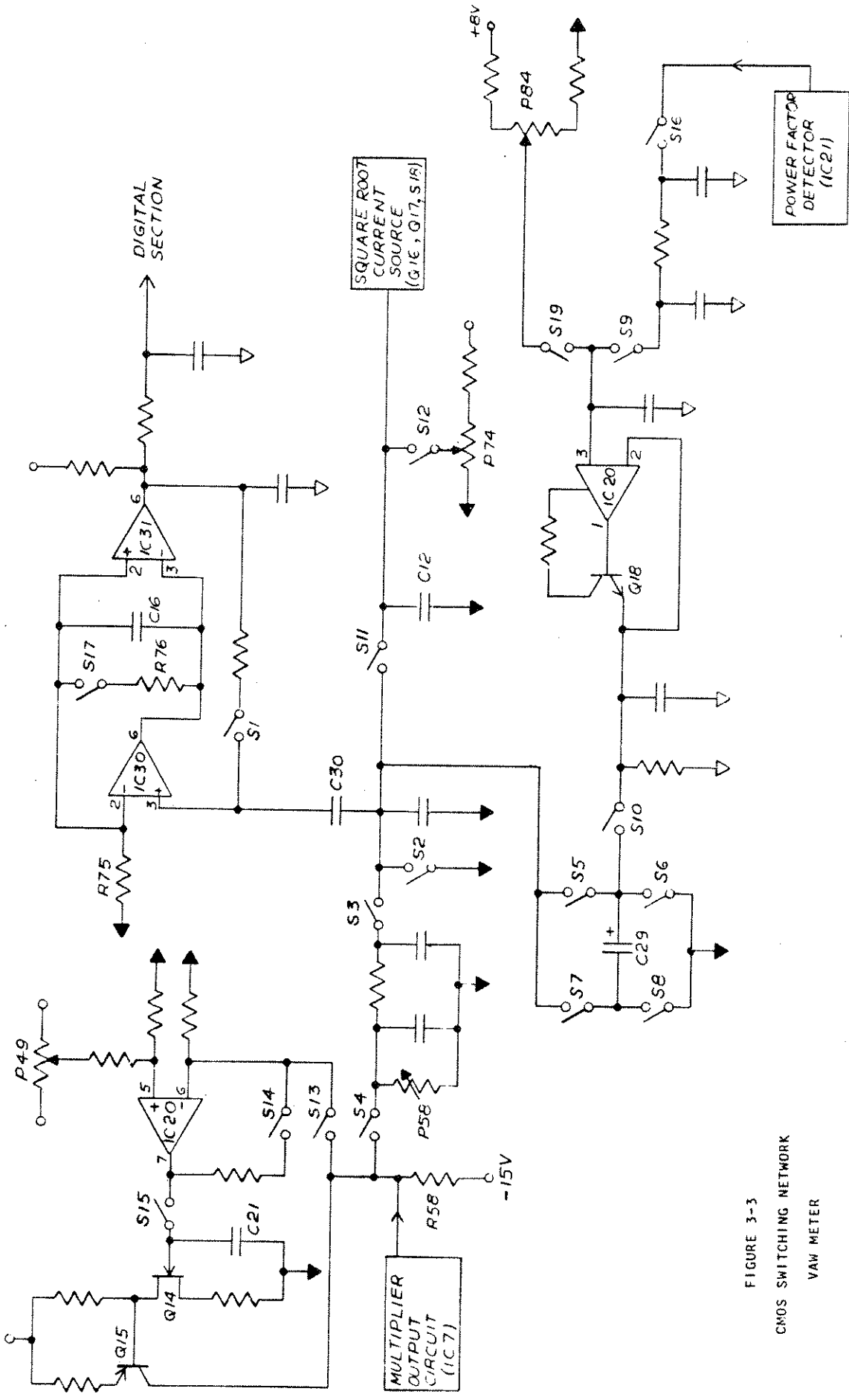

FIGURE 3-3  
CMOS SWITCHING NETWORK  
VAW METER

Table 3-1. Switch Drive Signals

| <u>Switch</u> | <u>Drive Signal *</u>   |
|---------------|---|
| S1, S2        | NOT ACTIVE or NOT LFC   |
| S3            | SIGNAL  |
| S4            | NOT LL pulse  |
| S5            | (REFERENCE) and (NP)  |
| S6, S7        | (REFERENCE) and (PP) and NOT (V or I)                         |
| S8            | (S5 drive) or NOT LFC   |
| S9            | "Power Factor" (from Function Switch via IC211)               |
| S10           | NOT LFC   |
| S11           | (REFERENCE) and (PP) and (V or I)                             |
| S12, S18      | Inverse of S11 drive (via IC229)                              |
| S13, S15      | LL pulse  |
| S14, S16      | NOT LL pulse  |
| S19           | NOT "Power Factor" (from Function Switch via IC211 and IC229) |

---

\*  
 "or" is a logical OR (Either)

"and" is a logical AND (coincidence)

NOT X is the inverse of X.

Switches are CLOSED when these signals are positive; otherwise OPEN.

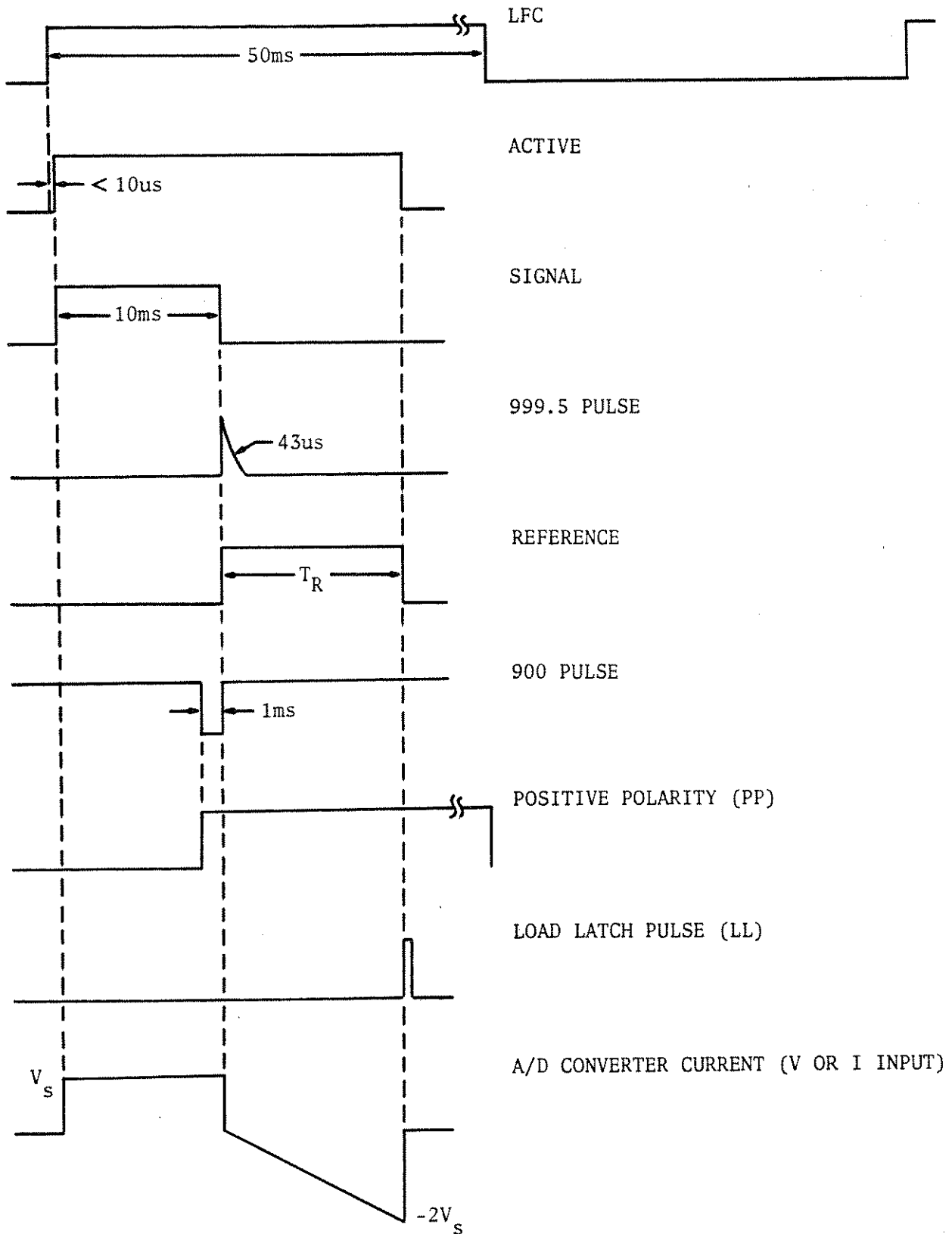

Fig. 3-4. Relative timing of the V-A-W Meter Control Signals.  
 (Shown for the case of "Full Scale" Voltage)

### 3-4-3. ANALOG/DIGITAL CONVERSION

The A/D conversion is accomplished by the combination of IC30 and IC31 together with a number of logic control circuits from the Digital Section and the digital counters on the Display Board.

IC30 and 31 have their own independent Auto-Zero operation. Whenever these IC's are not "actively" performing an A/D conversion--that is, whenever the signal ACTIVE is present\*--then S1 and S2 are closed while S3, 5, 7, 11 and 17 are open. The closure of S1 forms a loop of IC30 and IC31 that applies an "auto-zero" voltage to C30, via the ground connection supplied by S2. Since Pin 2 of IC30 is near zero volts during this period, the loop forces Pin 3 to near zero and discharges C16. During the "active" portion of the A/D conversion the bias voltage stored in C30 during the Auto-Zero cycle is added to (or subtracted from) the applied input voltage to remove the effects of long-term drift in the offset voltages of IC30.

The ACTIVE period of the A/D conversion is broken into two further periods, known as SIGNAL and REFERENCE. During the SIGNAL period, S3 closes and the output of the Filter Circuit is applied to IC30, Pin 3 via C30. C16 is charged during this interval by a current equal to the Filter output voltage divided by R75. As outlined in Section 3-5-4, the period of SIGNAL is 9.99 msec (999 cycles of a 100kHz signal derived from the 1MHZ crystal oscillator formed by a portion of IC218). At the end of this period S3 opens and either S11 (Voltage or Current) or S6 and S7 (Positive Power or Power Factor) or S5 and S8 (Negative Power or Power Factor) close for the length of time necessary to completely discharge C16 back to zero. This period is known as REFERENCE. The end of REFERENCE is generated by C16 reaching zero volts and causing IC31 (a comparator) to change state.

The length of REFERENCE is determined by counting a frequency of 100kHz, 200kHz, or 500kHz depending upon the Full Scale value of the RANGE and FUNCTION being measured. All of these frequencies are derived from the same 1 MHz crystal oscillator.

In the POWER measurement case the voltage applied to IC30, Pin 3 during the REFERENCE interval is a constant and the output COUNT is directly proportional to the Filter Output applied during the SIGNAL interval.

---

\* The switch drive for S1 and S2 consists of the "or"ing of NOT ACTIVE and NOT LFC. Since NOT LFC is the negative half cycle of the Low Frequency Clock it will never initiate the auto-zero cycle unless either NOT ACTIVE fails to appear or else the duration of ACTIVE exceeds the positive half of LFC. The second case is an overload condition that is limited by the appearance of NOT LFC.

When measuring VOLTAGE or CURRENT the voltage applied to Pin 3 of IC30 is a negative going ramp and the output COUNT is proportional to the SQUARE ROOT of the Filter Output applied during the SIGNAL interval.

When measuring POWER FACTOR (of sinusoidal-like input signals) the voltage applied during the REFERENCE interval is a voltage that is proportional to the VI product. Since the voltage applied during the SIGNAL interval was proportional to  $VI \cos \theta$ , the COUNT is proportional to  $\cos \theta$  or the POWER FACTOR.

#### 3-4-4. POWER FACTOR DETECTOR

For a sine wave current and a sine wave voltage the multiplier produces an output proportional to:

$$VI \cos \theta + VI \cos (2\omega t + \theta)$$

where V and I are RMS values of current and voltage and  $\theta$  is the angle between the current and voltage. For sinusoidal signals the term  $\cos \theta$  is known as the POWER FACTOR. The low pass filter consisting of R56, 57, C23 and 24 selects the first portion of the output, which is proportional to  $VI \cos \theta$ . IC21 receives the second term of the output, via a high pass filter, and rectifies it to obtain a signal proportional to the VI product alone. (In the high frequency case the phase angle is discarded by the rectification process.) This rectified dc term is filtered, controlled by switches S16 and S9, and used as the input to the reference amplifier to charge the reference capacitor C29 during ACTIVE periods. Thus when POWER FACTOR is requested and when the inputs are sinusoidal-like so that the rectification process yields a sensible term, then the A/D converter output is proportional to:

$$(VI \cos \theta) / (VI) \text{ or to } \cos \theta .$$

It will be clear from this description why the meter will read OVER-RANGE rather than zero when it is switched to POWER FACTOR with no inputs (or too small an input) are applied. The numerator will try to be zero; however so will the denominator, leading to an indeterminate state.

#### 3-4-5. SQUARE ROOT GENERATOR

The negative going ramp necessary for taking the square root in the VOLTAGE and CURRENT cases is generated by the temperature compensated current source charging a stable capacitor. S18 opens to turn on the current source (Q16 and Q17). S12 (two CMOS switches in parallel) discharges the capacitor, C12, between cycles and S11 connects the resultant ramp to the input of IC30 during the REFERENCE interval when either VOLTAGE or CURRENT is being measured. P66 controls the size of the constant current, hence the slope of the ramp, while P74 controls the initial offset of the ramp.

### 3-4-6. INPUT OVERLOAD DETECTORS

IC5 and IC6 are identical dual comparators that monitor the peak signals at the outputs of IC3 and IC4 respectively. These peak levels are compared with dc levels set by the R13/R14 and R24/R25 attenuators.

When any of the peak levels exceed the dc set points the INPUT OVERLOAD indicator flashes on. The brightness of the LED indicator gives some indication of the percentage of the time that the signals are spending in the overload region. For example, if equal peak amplitude SQUARE, SINE, and TRIANGULAR waves are used as inputs and adjusted to the "edge" of the overload then the LED will be "bright" for the SQUARE wave, "less bright" for the SINE wave, and "dim" for the TRIANGLE. The relative brightness of the LED will also depend somewhat upon the frequency of the overloading input. In general a given peak amplitude will give about the same apparent brightness between 10Hz and 100kHz. Below 10Hz there will be noticeable "flashing" and above 100kHz the detector efficiency begins to roll off.

THE FACT THAT THE "INPUT OVERLOAD" LAMPS FLASH DOES NOT MEAN THAT REASONABLE READING CAN NOT BE OBTAINED WITH THE V-A-W METER. ON ALL BUT THE 1000 V RANGE THE METER WILL HANDLE PEAK VALUES OF AT LEAST 3.5 TIMES THE NOMINAL FULL SCALE (i.e a 70 V peak on the 20 V scale) THE INPUT OVERLOAD LAMPS COME ON ABOUT 40 V HENCE THEY SERVE AS "WARNINGS" RATHER THAN INDICATORS OF TROUBLE.

### 3-5-0. CLOCKS AND TIMING - GENERAL

The V-A-W Meter has two basic clock signals and various timing signals that are derived from or controlled by these signals.

The Low Frequency Clock (LFC) is normally produced by squaring-up and dividing down the power line frequency. Usually for 60Hz operation the division ratio is set at six so that a basic LFC frequency of 10Hz is obtained.

The High Frequency Clock (HFC) is produced by divisions of 10, 5, or 2 from a 1MHz crystal oscillator. The division ratio is controlled by a set of digital logic. It depends upon the FUNCTION being measured, the FULL SCALE combination required by the RANGES, and the portion of the TIMING cycle involved.

Figure 3-4 illustrates some of the timing signals obtained from these clock signals.



### 3-5-1. LOW FREQUENCY CLOCK, LFC

The usual V-A-W Meter has a signal of line frequency introduced, via a twisted pair, to two holes marked A and B in the right rear corner of the main printed circuit board. This signal is clipped off by the resistor, R240, diode, D201, D202 combination, and then "squared-up" by two stages of inversion separated by RC filters. The final square wave is applied as an input to the programmable divider IC224. By choosing a pad, the desired division ratio is chosen. Normally the input signal is divided by 6 to produce 10 Hz LFC signal from a 60 Hz line frequency.

If for some reason either a different line derived frequency is desired or if one wishes to obtain a non-line derived value for LFC both are possible. Clarke-Hess can supply an option that allows the user to vary the basic (before division) clock frequency from 48 to 62 Hz so that possible beats with either "nearly" 50 Hz or "nearly" 60 Hz inputs may be avoided. One should consult the factory before changing LFC by more than 10-15%. Such changes will have effects on OVER RANGE capabilities, the rate of updating of the visual and BCD latch outputs, and other more subtle phenomena. To drive the LFC from an external source remove the twisted pair and apply a square wave of six times the desired LFC to the inputs A and B. (It will be necessary to tie point B to the circuit ground--say at the right end of C241 or C242.)

IC230 (7,8) is used to generate LFC. As with most of CMOS digital circuitry in the V-A-W Meter, the output levels of these circuits vary between a nominal value of zero and a nominal value of plus eight volts.

### 3-5-2. HIGH FREQUENCY CLOCK, HFC

The V-A-W Meter contains a 1 MHz crystal oscillator (IC218, Pins 2:5). This frequency is divided down in IC219 by a ratio of 10, 5, or 2. The division ratio is programmed by the logic circuitry of IC 212 and IC214 which are in turn driven by various other control signals derived from the FUNCTION switch, the RANGE switches, and other circuitry in the Digital Section of the V-A-W Meter. The division ratio is always 10 during the SIGNAL interval. Its value during the REFERENCE interval depends upon the FULL SCALE required by the Meter. The relationship is presented in Table 3-2. (The purpose of the crystal is to provide oscillator stability rather than frequency accuracy.)

Table 3-2.

| <u>FULL SCALE</u> | <u>DIVISION RATIO</u> | <u>HFC during REFERENCE</u> |
|-------------------|-----------------------|-----------------------------|
| 1000 digits       | 10                    | 100kHz                      |
| 2000 digits       | 5                     | 200kHz                      |
| 5000 digits       | 2                     | 500kHz                      |

HFC is transmitted to the Display Board via Pin 4 of Jack #1. It is also used as a timing signal in producing the ACTIVE pulse.

### 3-5-3. ACTIVE

A pulse, ACTIVE, and its inverse, NOT ACTIVE, are produced during the period that the V-A-W Meter is producing an A/D conversion. IC220 (CD4013) is the "Active" Latch.

The CD4013 consists of two D type latches with clocks (Pins 3,11), data (Pins 5, 9) reset (Pins 4, 10), Q (Pins 1, 13) and Q (Pins 2, 12) connections. The "data" is "clocked" into the latch on a Positive Going Transition (PGT). Pins 1, 2, 3, 4, 5 make up one latch while Pins 9, 10, 11, 12, and 13, make up the other. A positive input on "reset" sets the Q outputs "low" and the NOT Q " outputs "high".

Assume that initially both latches have been "reset". Now the first PGT of HFC that occurs after the PGT of LFC "clocks" the 9, 10, 11, 12, 13 latch. Pin 13 (Q) outputs ACTIVE, while Pin 12 (NOT Q) outputs NOT ACTIVE. The PGT of ACTIVE "clocks" the 1, 2, 3, 4, 5 latch which turns off the IC226 (8, 9, 10) gate and prevents further "clocking" of the first latch. (LFC provides the "data" input to both latches.)

The end of the ACTIVE is caused by a reset pulse applied to Pin 10. This pulse is produced in IC222 and IC238 (Pins 11,12,13) by suitable processing of the output from the analog comparator (IC31). To prevent ACTIVE from being accidentally terminated by a noise pulse during the SIGNAL period, IC207 (4, 5, 6) "ands" the reset pulse with NOT SIGNAL before it reaches the reset pin of IC220. (The other half of IC220 is reset by NOT LFC so that ACTIVE gets fresh start every cycle of LFC.)

Since the HFC and the LFC signals are normally not synchronized, there is up to 10 usec (the period of one 100kHz HFC cycle) uncertainty between the PGT of LFC and the PGT of ACTIVE.

ACTIVE (and NOT ACTIVE) are used as control signals on the main printed circuit board as well as an HFC gating signal on the DISPLAY BOARD.

### 3-5-4. SIGNAL

SIGNAL is fixed time interval signal that is produced by counting the crystal controlled 100kHz signal in IC405-408 on the DISPLAY BOARD.

If we assume that the 9, 10, 11, 12, 13 latch of IC225 is in the reset condition at the start of ACTIVE, then ACTIVE is "anded" (IC226, Pins 11, 12, 13) with NOT Q of this latch to start SIGNAL (and via 11, 12 of IC230 to produce NOT SIGNAL).

On the DISPLAY BOARD the Negative Going Transition (NGT) of LL is used to reset the counters (IC405 to IC408) to zero. IC402, Pins 9-13 and IC401, Pins 11, 12, 13 produce the negative going "clear" pulse. At the same time ACTIVE is turning on IC401, Pins 4, 5, 6 so that the counter can receive the 100kHz NOT HFC pulses at its "clock" input. Thus the counter starts its count with the PGT of NOT HFC that follows the PGT of HFC that started ACTIVE. The SN74143 (IC405-408) counter has an NGT pulse that occurs on the count of 9. These pulses from IC405-IC407 are combined with the gated NOT HFC in IC402 (Pins 1, 2, 3, 4, 5) to produce a positive going pulse that occurs 999-1/2 counts after the reset. This pulse is "stretched" and gated with SIGNAL (IC226, Pins 8, 9, 10) to produce the "clock" signal for the IC225 latch. (LFC is providing the "data" input, while "resetting" is accomplished at the end of each measurement cycle by NOT LFC.)

The "clocking" of the latch (IC226) terminates SIGNAL and starts REFERENCE.

The actual duration of SIGNAL is very close to 9.99 msec. The difference is due to circuit delays of about 200 nsec (through IC402, CR401, R409, C403, and IC226) and the lack of complete symmetry in HFC. The "extra" 1/2 cycle at the end of 999-1/2 counts is removed by the fact that the inversion of HFC in IC401 (4, 5, 6) allows the first count of IC405 to occur when SIGNAL is only a half a count wide.

In addition to its role as a switch control signal, the trailing edge (PGT) of SIGNAL clears the IC405-IC408 counter to 000 so that it is prepared to count the REFERENCE interval.

### 3-5-5. REFERENCE

As outlined in the previous section the 999-1/2 count from the DISPLAY BOARD "clocks" the IC225 latch. When Q (pin 13) of this latch goes high it combines with ACTIVE in IC226 (1, 2, 3) to form REFERENCE. IC218 (14,15) inverts the signal to make NOT REFERENCE.

REFERENCE is terminated by the termination of ACTIVE which turns off the AND gate IC226 (1, 2, 3).

REFERENCE (and its inverse) have a direct role in driving six of the CMOS switches listed in Table 3-1. In addition they play an important part in setting the IC212/IC214 programming of IC219. This programming sets the frequency of HFC during the REFERENCE interval and hence the FULL SCALE capability of the V-A-W Meter.

### 3-5-6. LOAD LATCH PULSE, LL, and NOT LL

The LOAD LATCH pulses, LL and NOT LL, are formed by IC233, which is a CD4013 connected as a monostable multivibrator. The multivibrator is

"clocked" (triggered) by the PGT of NOT ACTIVE that occurs at the end of ACTIVE and hence at the end of REFERENCE. The pulse width is approximately 60% of the R251, C251 product. Since the circuit is a monostable multivibrator it "resets" itself. The LL pulse for driving the CMOS switches is derived from the NOT LL pulse via an inverter in IC229.

The LL pulse "moves" the counter output, at the end of REFERENCE, into the BCD latches and into the digit display driver latches within the SN74143's (IC405-408). If this "updating" is not desired, then grounding the HOLD input (IC401, Pin 10 and J3, Pin9) will prevent the LL pulse from reaching the counters.

The LL pulse (or its reverse) also drives the Analog Section Auto Zero Circuitry.

### 3-5-7. POLARITY SIGNALS

The Positive Polarity Pulse, PP, and the Negative Polarity Pulse, NP, are generated in the Polarity Latch, IC231. The operation of the CD4013 with its dual Type D latches is similar to the description of the generation of ACTIVE. Both latches are reset by LFC. The latches are both clocked by the NGT that occurs on the 900th count during the SIGNAL period. IC238(1, 2, 3) provides gating while C261, R261, D261, and IC230 (14, 15) shape and invert the pulse. The latch "data" is the state of the comparator output at this instant. That is, the decision as to whether a positive or a negative signal is being fed into IC30 is made in a 1.5 usec interval 9 msec after the application of the signal.

The NP pulse causes the MINUS lamp to flash. The choice of NP or PP decides the polarity of the reference voltage (supplied by C29) that will be applied to the IC30 input during REFERENCE when measuring POWER or POWER FACTOR. Since the VOLTAGE and CURRENT readings must always be positive (except for zero input) the choice does not arise when measuring V or I.

IC222 (1, 2, 3, 11, 12, 13), IC230 (4, 5, 9, 10, 14, 15) provide inversions and gating necessary for the proper operation of the polarity latches.

### 3-6-0. DIGITAL CONTROL CIRCUITRY

The group of circuits discussed in this section receive dc signals from the FUNCTION switch (or its paralleled REMOTE inputs) and from the RANGE switches. They combine, code, process, and level shift these inputs to set the DECIAML POINT, the FULL SCALE range, and the INTERCONNECTIONS in CMOS switches IC11, 12, and 13. These functions are contained in IC200, 201, 203, 211 and 240. Transistors Q220, 221 and 222 and their associated resistors are also involved in these operations.

### 3-6-1. DECIMAL POINT, FUNCTION, AND FULL SCALE MEMORIES

IC202 and IC203 are 1024 Bit Programmable Read Only Memories (PROM's) that have been programmed to provide the necessary decoding operations between the input RANGE and FUNCTION switches and the rest of the instrument. IC202 has inputs on Pins 1-7 and 15 and outputs (labeled on Drawing 25516) to the MILLIWATT lamp and the DECIMAL POINTS on the three right hand digits of the display.

IC203 has inputs 1, 2, and 15 tied to +5 V and inputs on Pins 3-7 and outputs on Pins 9, 10, and 11.

Table 3-3.

| <u>IC203 Pin</u> | <u>Should go LOW<br/>when FULL SCALE is:</u> | <u>IC219 division<br/>ratio is:</u> |
|------------------|--|-------------------------------------|
| 9                | 1000   | 10                                  |
| 10               | 2000   | 5                                   |
| 11               | 5000   | 2                                   |

IC211 inverts the outputs from IC202 and "level shifts" them from the +5 V logic level of IC203 up to the +8 V level of the CMOS circuitry. Both IC202 and 203 operate from the +5 V supply.

### 3-6-2. INPUT DECODING CIRCUITRY

IC200 and IC201 together with Q20 combine the inputs from the FUNCTION switch of its paralleled REMOTE pads to form static driving signals for IC202 and IC203 as well as providing the settings for the "static" switches in IC11, 12, and 13. In addition to its logic function, IC200 also serves as a "level shifter" from +5V inputs to the +8V CMOS logic. Both these IC's operate from the +5V Power Supply.

### 3-6-3. SWITCH DRIVERS (IC11, 12, and 13)

The bulk of the logic circuitry is made up of CMOS circuits that operate from a +8 V power supply. The various switching internal functions are preformed by CMOS switches (usually CD4016) that require both positive and negative biases to provide proper dynamic ranges for all required inputs. To drive these switches between their ON and their OFF positions requires a switch driver to "translate" the 0 to +8 V input swing to a -6 V to +8 V

output swing. The CD4054(IC240) performs this function for four of the inputs required by IC11, 12, and 13. The fifth input to these switches is provided by the Q221, Q222 combination. On Drawing 25516 (Digital Section) the switch drive outputs (on the right side) are in the same order as the inputs (on the left side). That is, Pin 13 "drives" Pin 4, Pin 15 "drives" Pin 3, and so forth.

### 3-7. "DYNAMIC" SWITCH DRIVERS

The nineteen "output" CMOS switches of Figure 3-3, Table 3-1, are CD4054 units that serve to translate 0 to +8 V levels to -6 V to +8 V levels. Thus if the signals of Figure 3-4 are measured on the input side of these IC's the "low" side will be ground while measuring the same signal on the output side will find the "low" side at -6 V. As with IC240 the inputs "proceed" across the modules on Drawing 25516 to their respective outputs.

IC239, 229, and 238 contribute logic circuitry that combines signals to produce the drive signals of Table 3-1.

### 3-8-0. OVER AND UNDER RANGE CIRCUITRY

IC's 232 and 234 together with Q219 and IC207 (1, 2, 3) make up the sensing and driving circuitry that determine when the OUTPUT OVER RANGE lamp flashes and when the V, I readings are low enough that DISPLAY flashing (periodic blanking) should occur.

### 3-8-1. OUTPUT OVER RANGE

The 1, 2, 3, 4, 5 portion of IC234 forms a CD4013 monostable multivibrator similar to the Load Latch monostable, IC233. The monostable is "clocked" (triggered) by the PGT of NOT SIGNAL. That is, the monostable turns on at the end of SIGNAL which is the same as the beginning of REFERENCE. The pulse width is set by adjusting P252 or in an extreme case by changing C252 or R252.

The PGT of the Q output is used as the clock for the 1, 2, 3, 4, 5 portion of IC232 (CD4013) operating as a normal latch. The "data" for this latch (Pin 5) is ACTIVE. Thus if ACTIVE is still present at the end of the monostable pulse then REFERENCE is deemed to have been too long and the OVER RANGE lamp is turned on via Q219. Since the IC232 latch is not reset until the beginning of SIGNAL the LED is on (when on at all) for between 70% and 80% of the time.

AS WITH THE INPUT OVERLOAD ONE SHOULD INTERPRET THE OUTPUT LAMP AS A "WARNING" RATHER THAN AS AN INDICATOR. THE LAMP IS NORMALLY SET TO COME ON WITH AND RMS INPUT OF 1.5 TIMES THE NOMINAL FULL SCALE VALUE. WITH SINE WAVE INPUT THE INSTRUMENT WILL BE WELL WITHIN ITS SPECIFICATIONS UP TO AT LEAST 1.7 TIMES THE NOMINAL FULL SCALE VALUE OF A RANGE.

By adjusting P252 the OVER RANGE can be set to come on from about 10% above FULL SCALE to about 90% above FULL SCALE. It is normally set at the factory to come on at about 50% above FULL SCALE.

### 3-8-2. INPUT UNDER RANGE

The 9, 10, 11, 12, 13 portion of IC234 (CD4013) makes up a monostable multivibrator that senses whether the input reading is too low. The monostable is "clocked" (triggered) by the PGT at the end of NOT SIGNAL (the beginning of REFERENCE). The Q output (pin 13) of the monostable provides the "data" input (Pin 9) to the 9, 10, 11, 12, 13 portion of IC232 (CD4013) which functions as a normal latch. In this case the latch is "clocked" (Pin 11) by the PGT at the end of NOT ACTIVE (the end of REFERENCE). Thus if the monostable pulse is still there when ACTIVE ends then REFERENCE is deemed to be too short for a valid Voltage or Current reading. The latch output (Pin 3) is "anded" with the V or I signal from IC201 in IC207 (1, 2, 3) to produce a "blanking" signal for the DISPLAY driver circuits in IC405-408 (Pin 5 of each IC). The SN74143 (IC405-408) blanks when Pin 5 is HIGH. Diode D207 is included to isolate the +8 V "on" output of IC207 from the +5 V logic of the SN74143. If IC207 is removed (or fails) or if D207 is removed (or fails) then the display will blank unless the common connection to Pin 5 on IC405-408 is grounded.

P253 allows one to adjust the width of the monostable pulse and hence the point at which UNDER RANGE blanking starts. Since the latch is reset by SIGNAL the display will normally be blanked for nearly 90% of the time, assuming that it is blanked at all. Blanking is normally set at the factory to occur at about 7% of FULL SCALE.

### 3-9-0. POWER SUPPLIES

The V-A-W Meter has five dc supply voltages. All supplies are well regulated to remove line voltage variations.

#### 3-9-1. +5 V SUPPLY

The +5 V, 1 Ampere supply is produced by a full wave rectified, capacitor input dc supply feeding an LM340K-5 (or equivalent) regulator. This power supply feeds the DISPLAY board as well as IC200, 201, 202, 203, and 211 on the main printed circuit board.

### 3-9-2 ±15 V POWER SUPPLIES.

The + 15 v supply is controlled by IC 310 which is a u723 voltage regulator adjusted for a nominal output of +15 V. The voltage reference for IC 310 comes from IC303 via R316. The ±15 V supplies are powered from a nominal ±20 V rectifier/capacitor filter combination. The -15 V supply is "mirrored" from the +15 V supply by the 1-2-3 amplifier in IC 320(LM1458) and the voltage divider R317/R318. Q311 (2N2905A) is the -15V pass transistor.

The ±15V supplies feed the multiplier (IC7), its output circuitry, the positive input to the input overload detectors (IC5 & IC6), some of the DC control and nulling potentiometers, and the voltage box circuitry. (In the voltage box the CMOS digital logic gets ±10 V via zener diodes Z130 & Z131.

### 3-9-3 + 8 V and - 6 V SUPPLIES.

The + 8 V supply is controlled by IC303 (u723) adjusted for a nominal output of + 8 V. The + 20 V input is pre-regulated with the R301/Z301 combination before being supplied to IC303.

The - 6 v supply is "mirrored" from the + 8 V supply via the 5-6-7 section of IC320(LM1458) and the voltage divider R307/R308. The pass transistor, Q304, for the - 6 V supply is fed from the - 20 V input by the pre-regulator combination of R302/Z302.

The + 8 V supply is used by all the CMOS logic circuitry and by all the main board analog circuitry except the multiplier (IC7).

The - 6 v supply is used all the analog circuitry, except IC7 and IC 20, by all the main board CMOS switches (CD4016) and main board level shifters (CD4054), and by the input overload detectors, IC5 and IC6.

### 3-10. OPTIONS.

The V-A-W meters may have external transformers and shunts to extend their ranges. They may also have various circuit options including isolated IEEE-488 TALKER/LISTENER outputs, isolated BCD outputs, isolated REMOTE control of functions, an isolated analog output, or an isolated pulse output proportional to energy or ampere hours. If such options are included with a particular instrument then the "instruction manual" material for such an option is either supplied in a separate manual or is bound at the end of this Instruction Manual.



## IV. REPAIR AND ADJUSTMENT

### 4-0. INTRODUCTION

Care has been taken to protect the V-A-W Meter from the "hostile" circumstances in which it is often expected to operate. In spite of these precautions accidents may happen or components may occasionally fail for no apparent reason. This chapter attempts to present a rational approach toward restoring the V-A-W Meter to service should failure occur.

If trouble cannot be eliminated through the use of these instructions, please write or telephone our Service Department giving the instrument type number, the trouble, and the steps taken to remedy it. By return mail, or on the telephone, you will either receive simple instruction as to the cause and repair of the defect, or authorization to return the instrument to our factory for repair or replacement.

Instruments no longer covered by our warranty will be repaired or recalibrated after proper customer authorization is received to cover the estimated costs.

#### Printed Circuit Wiring

If it should be necessary to remove a wire or component from the printed circuit board, one should use reasonable care and low wattage (less than 50 W) soldering irons. (Soldering guns are NOT recommended.) High wattage soldering irons may damage either the board or the wiring. A solder "snuffer" or a solder absorbent such as "Dri Wick" may be helpful in removing old solder before attempting to remount a component or to reconnect a wire.

In attempting any repair one should make maximum use of the V-A-W Meter's own indicators as well as any information about the past history of the instrument that may indicate a likely area to explore for trouble

The V-A-W Meter has a visual digital DISPLAY as well as INPUT and OUTPUT OVER RANGE LED indicators. By observing the DISPLAY and the LED's as one switches through the FUNCTIONS and the RANGES, one can often greatly narrow down the possible sources of trouble.

4-1. POWER SUPPLY VOLTAGES(Drawing 25518)

Once the top cover of the instrument has been removed (two screws on each side of the instrument) it only takes a moment to check the five power supply voltages. A test point for each voltage is labeled. All of them occur on the rear 8 cm (3 inches) of the main printed circuit board; that is, back close to the various regulators. The range of acceptable values for the power supplies is listed in the table below:

Table 4-1. Acceptable Power Supply Values

| <u>Nominal Value</u> | <u>Acceptable Range</u> |
|----------------------|-------------------------|
| +15 V                | +14.5 to +15.1 V        |
| -15 V                | -14.5 to -15.1 V        |
| +8 V                 | +7.5 to +8.1 V          |
| -6 V                 | -5.5 to -6.3 V          |
| +5 V                 | +4.8 to +5.2 V          |

If a voltage is wrong, but not zero, try switching off the line power momentarily in case a brief short circuit has caused a supply to "latch-up" improperly.

If either the +8 V or -6 V supply is low, a check of the +11 V and -9 V zener regulated supplies (Z301, Z302) will indicate whether the supply is trying to draw excess current. If either of these voltages is low then the chances are that some input amplifier and/or some CD4016 switch has been "zapped" into a state that is causing it to draw more current than it should. At this point a "touch test" may indicate the excessively hot culprit.

Since the positive supplies, IC303 and IC310, are in sockets they may be interchanged BRIEFLY if one of them is suspected of being defective. They should be returned to their original sockets.

If either negative supply is "gone" then the appropriate pass transistor, Q304 or Q11 is the most likely suspect. IC320 controls both of these transistors so it is also a possible source of a problem.

Excessive ripple - at the line frequency instead of at twice it - will result from the failure (open) of any one of the rectifiers, D301 to D306.

If IC removal is undertaken to remove an apparent cause of excess loading one should take two precautions:

(1) Turn off the power when removing and installing each I.C.

(2) Keep track of the position of each I.C so that it can be restored to the same position if it is not defective.

#### 4-2 INPUT PROTECTION.

The three lowest current ranges have a 1.5 ampere, fast acting fuse in series with their shunts. The fuse is followed by a set of series connected diodes, D110-D113 that should limit the shunt voltage to 1.5 V until the fuse blows. In some instruments this fuse is located on the front panel near the CURRENT input terminals. On other units it is located on the printed circuit board behind the CURRENT terminals. In the second case one must remove the bottom of the V-A-W meter to reach the fuse. If the three low CURRENT ranges do not operate and an ohmmeter reading across the two right hand CURRENT terminals exceeds 20 ohms then this fuse is the most likely source of the trouble.

To further protect the input current amplifier a transistor-diode limiter pair is located on the main board just in front of IC 1.

The two COMMON terminals in all instruments with serial numbers above 30,000 are CONNECTED TOGETHER INTERNALLY. (In earlier instruments the user needed to make an EXTERNAL connection between these two terminals.) Any external power source connected across these terminals will see a short circuit.

In spite of the fact that the two COMMON terminals are internally connected one should always connect a load so that the load current flows into and out of the two CURRENT terminals and not through the internal COMMON to COMMON connection.

#### 4-3-1. ANALOG SECTION - GENERAL

If the fuses are correct but the INPUT OVERLOAD lamp still comes on with no input then the chances are good that either there is a defective comparator (IC5 or IC6) or that one of the input operational amplifiers has been "blown up". If the lamp stays on for all FUNCTION settings then the comparator is most likely to be defective, while if the lamp only comes on for CURRENT then IC1 is most likely to be defective, and so forth.

One may "trouble shoot" the VOLTAGE or CURRENT input amplifiers for gross defects by using a DC voltmeter or an oscilloscope as a DC voltmeter. With no inputs and the FUNCTION switch on CURRENT then the voltage from the right end of R8 to the left end of R9 (the output of IC1) should be within 1 millivolt of zero. With the FUNCTION switch on VOLTAGE and the RANGE button on 1000 V then the voltages between the right end of R5 and the left end of R4 should both be within 1 millivolt of zero.

Large (3 to 8 Volt) values for any of these voltages usually imply a defective IC (CA3130 or CD4016). Removal of the IC should remove the offending voltage. When removing IC's one should turn off the power. After checking the units one should return the good units to their original positions. If TP-1 still has a "large" DC voltage with IC2 (CA3130) removed then one should check the components in the "voltage amplifier box". The circuitry in this box (FOR INSTRUMENTS WITH S/N GREATER THAN 30,000) has an auto-zero circuit that produces a 50-60 usec pulse every 100 milliseconds. Some DC voltmeters may give improper readings in the presence of this pulse. A one volt amplitude for this pulse - on an oscilloscope - is normal in instruments with a serial number above 30,000.

IC21, the Power Factor Detector, may be used as a substitute CA3130 to replace a "front end" unit believed to be defective. If IC1, or IC2 should have to be replaced then one must readjust the appropriate DC offset control (see Section 4-6-1).

The V-A-W Meter provides a DC test signal via the front end of R99 (a 3.1 kohm resistor connected from the +15V supply and located at the extreme left side of the Main Board slightly in front of IC7). Connecting the front end of R99 to the 5mA terminal and connecting the current COMMON terminal to the internal voltage ground should give a DISPLAY current reading of approximately 5mA ( $\pm 5\%$ ) while connecting to the 20V input should give a DISPLAY voltage reading between 14.5 and 15 volts. In either case a high impedance DC voltmeter should give a reading in the neighborhood of 700 millivolts between the right end R56 (located in front of P58) and one of the internal COMMON test points. The same internal test signal should give DC readings of approximately 100 millivolts at the output of IC1 for a CURRENT input and at the output of IC2 for a VOLTAGE input.

#### 4-3-2. AUTO-ZERO

The operation of the AUTO-ZERO circuit is outlined in Section 3-4-2. If it does not seem to operate properly one should insure that both the LL and the NOT LL pulses exist at their switch driver outputs and that the appropriate switches are functioning. The LL and the NOT LL pulses are generated in IC233. The LL pulse used in driving the "switch driver" IC242 is derived from the inverse pulse via an inverter (Pins 6 and 7) contained in IC229. The LL pulse used in the Display Board comes directly from the IC233. A dc input at either voltage or current input should yield a signal across R58 that drops to zero once per LFC cycle for the LL period. Synchronizing the oscilloscope with the leading edge of the LL pulse will allow the easy examination of this 80 usec pulse. Varying P49 should cause the "bottom" of the pulse to "track" P49 as well as causing the instrument zero to vary. (Measure the "zero" with no input signal, and the FUNCTION switch on POWER. If the IC252 "drive" signals (Pins 5, 6, 12 and 13) are proper then Auto-Zero failure is most likely caused by a fault in IC20, Q14, or Q15.

#### 4-3-3. INTEGRATOR/COMPARATOR/DIGITAL SECTION

For testing purposes the V-A-W Meter may be split into TWO parts by removing IC252. With this IC removed the output DISPLAY should read approximately 000. Applying a test signal (about 700 millivolts) from the left end of R81 (from the front) to the right end of R56 should cause the DISPLAY to read approximately "Full Scale" for VOLTAGE, CURRENT, POWER, or POWER x10. In each case the decimal point should be in the appropriate position. If the proper displays are NOT obtained then using an oscilloscope to examine the waveshapes of Figure 3-4 (synchronize with the positive going transition of the LFC signal) will provide some clues as to which portion of the circuit is not functioning properly. The signal at the left end of R75 is often particularly instructive. For the VOLTAGE and CURRENT cases it is shown in Figure 3-4. For the POWER case it should go positive about 700 millivolts for 10 milliseconds then negative the same amount for the same length of time.

If trouble is suspected in the CLOCK or DIGITAL circuits then leave the V-A-W Meter in this "split" condition while examining those circuits.

#### 4-4. CLOCK AND TIMING CIRCUITRY

All the signals shown in Figure 3-4 should be observable at the appropriate points in Drawing 25516 as should all the switch drive signals listed in Table 3-1. (Be sure that the FUNCTION switch is in the proper position for any particular observation.) In addition the HFC should be observable at Pin 1 of IC219. Since HFC should change frequency during REFERENCE whenever the FULL SCALE value is other than 1000, one should see a change in the "density" of HFC if one synchronizes on the PGT of LFC and observes more than 10 msec worth of HFC. (Unless a signal is fed into IC30, REFERENCE may be so short that no change is observed.)

If a given signal is absent then either some logic circuit is:

- (a) Failing to receive dc power.
- (b) Failing to pass the input signals properly to the output.
- (c) Being loaded by an accidental short circuit or some other malfunctioning circuit element.

Both the 900-999 pulse and 999-1/2 pulse are vital to the proper operation of the instrument. Failure of either of these pulses indicates either trouble on the DISPLAY board or trouble in the communications between the two boards.

If both these pulses are present, but the DISPLAY is blanked then IC207 and/or D207 should be checked to insure that Pin 5 of the counters (IC405-408) is being held low so that blanking does NOT occur.

#### 4-5. DIGITAL CONTROL LOGIC/SPECIALIZED CIRCUITS

If the apparent trouble is traced to one of the specialized circuits (OVER RANGE, etc.) or to the DIGITAL LOGIC circuitry then simple IC substitution (turn off the power while removing and replacing IC's) may be the fastest trouble shooting method. The PROM operation (IC202 and IC203) may be checked with a voltmeter or oscilloscope by following the description in Section 3-6-1 while using Drawing 25516 to locate the appropriate measurement points. (If either of the PROM's should require replacement, contact CLARKE-HESS. Substituting an unprogrammed SN74S387 will NOT result in proper operation.)

#### 4-6-0. ADJUSTMENT PROCEDURE AFTER IC REPLACEMENT IN THE ANALOG SECTION

Table 4-1 lists all of the internal controls in the V-A-W Meter. Hopefully you, as a user, will never need to adjust any of them. The adjustments possible with P252 and P253 have been discussed in Sections 3-8-1 and 3-8-2 and will not be repeated here. All of the other controls are related to the analog portion of the circuitry. Their inter-relations and adjustments are summarized here to aid in their readjustment should any of the active elements in the Voltage Attenuator Board or in the Analog Section of the main printed circuit board ever require replacement.

##### 4-6-1. INPUT DC OFFSET CONTROLS, P2, 12, and 130

If IC1, or IC2 ever need replacement then the appropriate dc offset control will probably require readjustment. Before making any of these adjustments in a final fashion the instrument should be allowed a 30 minute warm-up.

To adjust P12 (IC1 replaced) connect a digital voltmeter with a resolution of 0.1 mV between the left end (FTF) of R9 and the right end of R8. Place the FUNCTION switch on CURRENT (no input). Adjust P12 to within  $\pm 0.3$  mV of 0.0 mV. There may be some small variation as different current ranges are selected.

To adjust P2 (IC2 replaced). Place the "high" side of the voltmeter to the left end (FTF) of R4 and adjust P2 so as to obtain less than  $\pm 0.1$  mV with the RANGE switch on 1000 V.

If Q 130 in the voltage box should ever have to be replaced attempt to choose a transistor with a gate-source "pinch off" voltage of 1 V or less. After the replacement P130 will need to be adjusted in conjunction with P2 and P46. As an initial adjustment connect the voltmeter as in the P2 adjustment and with the RANGE switch on 20 V adjust P130 for a reading of about -2.5 mV. Now recheck the P2 adjustment with the RANGE on 1000 V. Leave the final adjustment of P130 until the adjustment of P46 as explained in section 4-6-3.

Table 4-2.

Table of Internal Adjustments

MAIN PRINTED CIRCUIT BOARD

|      |  |
|------|--|
| P1   | Voltage Channel Gain Equalization            |
| P2   | Voltage Channel Second Stage DC Offset       |
| P12  | Current Channel First Stage DC Offset        |
| P20  | Multiplier Crossover Control (Voltage Input) |
| P28  | Multiplier Crossover Control (Current Input) |
| C39  | Low Power Factor Phase Adjustment            |
| P44  | Multiplier DC Offset (Voltage Input)         |
| P46  | Multiplier DC Offset (Current Input)         |
| P49  | AUTO ZERO Adjustment                         |
| C51  | 5 mA Frequency Compensation                  |
| P58  | Overall Gain Control                         |
| P61  | Power Factor "Full Scale" Adjustment         |
| P63  | Power Factor "Bias" Adjustment               |
| P66  | Current "Full Scale" Adjustment              |
| P74  | Voltage "1/10 Scale" Adjustment              |
| P84  | Power "Full Scale" Adjustment                |
| P119 | 50 mA Frequency Adjustment                   |

CURRENT ATTENUATOR BOARD

|      |                                       |
|------|---------------------------------------|
| P114 | 5 Ampere Range Frequency Compensation |
| P115 | 500mA Frequency Compensation          |

VOLTAGE ATTENUATOR BOARD

|      |                                       |
|------|---------------------------------------|
| P130 | Voltage Channel First Stage DC Offset |
| C133 | Voltage Frequency Compensation        |
| P138 | 1000 V Range Adjustment               |
| P140 | 200 V Range Adjustment                |

MAIN PRINTED CIRCUIT BOARD

|      |  |
|------|--|
| P252 | Output Overload Pulse Width Adjustment                         |
| P253 | Voltage and Current Voltage Under-Range Pulse Width Adjustment |

#### 4-6-2. MULTIPLIER CROSSOVER CONTROLS

The adjustment for P20 and for P28 is similar. The Difference between the two adjustments is that to adjust P20 one applies a variable amplitude sinusoidal voltage to the VOLTAGE terminals while to adjust P28 one applies a variable amplitude sinusoidal current to the CURRENT terminals. The RANGES should be chosen so that input may be varied between zero and twice FULL SCALE.

In both cases the FUNCTION switch is placed on POWER.

These adjustments should not be necessary unless the multiplier (IC7) is replaced. The overall adjustment will be simplified if the voltages and currents employed in this section have minimal dc components; that is, if they are ac coupled.

With a frequency in the neighborhood of 1kHz vary the VOLTAGE from zero to twice full scale and adjust P20 so that the output display does not vary more than  $\pm 1$  digit. If adjustment is not possible it may be necessary to shift the connection on the PADS just a few resistors behind P20 (between R30 and R31). Change the connection between the center pad and one of the outside pads.

The adjustment should hold within  $\pm 2$  digits as the frequency is varied from 100Hz to 40kHz.

To adjust P28 apply a CURRENT input and repeat. (In this case, pushing the 1000 V VOLTAGE Range will make the FULL SCALE reading 5000 instead of 1000, hence will offer FIVE times the resolution of the previous case.

The appropriate PADS for this case are located beside IC7.

#### 4-6-3. MULTIPLIER DC OFFSET CONTROLS

The internal DC test signal from the front end of R99 may be used to check the adjustment of these two offsets and if necessary to "trim" them before making extensive DC measurements with the V-A-W Meter. (Ideally one should use alternating positive and negative DC values for this adjustment; however, a positive DC value is sufficient for small "trimming" adjustments.) To check the adjustments of P44 (DC Voltage Input) and P46 (DC Current Input) Place the FUNCTION switch on POWER. MAKE SURE THAT THE ADJUSTMENTS OF SECTION 4-6-1 ARE DONE BEFORE MAKING ANY ADJUSTMENT OF P44 or P46!

Connect the front of R99 to the 20 V terminal and note the reading. Ideally it should be 000. Adjust P44 to make it zero. Connect the front end of R99 to the 5 mA input. Place the VOLTAGE RANGE on 1000 V and note the POWER reading. If it is not 000 then adjust P46 to make it zero. Change the VOLTAGE RANGE to the 20 V position and adjust P130 (in the Voltage Attenuator Box) to



return the POWER reading to 000. External DC drives of  $\pm 30$  Volts and  $\pm 7.5$  mA may be substituted for the internal test signal to gain more resolution in making these adjustments. With  $\pm$  drive signals the POWER readings should be symmetrical around 000.

#### 4-6-4. MULTIPLIER LINEARITY

CLARKE-HESS may have made various second order "linearity" corrections for a specific IC7. These corrections should not require adjustment. If IC7 should ever fail or be destroyed a replacement MC1595 will allow the Model 255 to operate, after readjusting the controls P20, 28, 44, and 46 and recalibrating the absolute gain with P58. If IC7 should ever require replacement the best thing to do is to check with the factory as to the desirability of returning the instrument for a complete recalibration.

#### 4-6-5. OTHER CONTROLS

If the multiplier has been changed then it is likely that P58, the overall gain control, will have to be readjusted. This should be done for FULL SCALE reading on CURRENT, VOLTAGE, and POWER. All the readings should be proper. If they are not then one should return to the appropriate adjustment section of Chapter II for details of proper adjustment. If the VOLTAGE and CURRENT ranges track each other they may be made "correct" at Full SCALE with P58 and the POWER readings adjusted at FULL SCALE with P84. The details of the other controls will be found in the appropriate sections of Chapter II. Except for P61, which will require readjustment if P58 is adjusted, none of the other controls should require attention because of the replacement of an integrated circuit.

If any of the amplifiers (IC1, 2, 3, or 4) is changed then the high frequency (above 100kHz) response may be slightly changed. Sections 2-4 through 2-7 indicate the procedure to check and to readjust these responses.



## V. REPLACEMENT PARTS

### 5-1. INTRODUCTION

This section contains a list of replacement parts for the Digital V-A-W Meter and the names of typical manufactures of such parts. Any of these replacements part may be obtained from CLARKE-HESS. To obtain a part include:

- a. The circuit reference number of the part.
- b. A brief description of the part.
- c. The instrument model and serial number.
- d. The quantity desired.

Send the order to CLARKE-HESS at the address on the front of the Instruction Manual. Telephone (212) 255-2940

### 5-2. LIST OF MANUFACTURERS.

The following list contains the key to the abbreviations in the parts list. The list presents both the name and the address of the manufacturer as well as the code numbers ( where available) for the manufacturers as listed in the Federal Supply code for Manufacturers Cataloging Handbooks H4-1 (Name to Code). The list order is Abbreviations/Federal Supply Code Number/ Company Name/ Company Address.

| <u>Abb.</u> | <u>F.S.<br/>Code</u> | <u>Company Name</u>                                       | <u>Company Address</u> |
|-------------|----------------------|---|------------------------|
| AB          | 01121                | Allen-Bradley Corp.                                       | Milwaukee, Wisc.       |
| AL          | 95146                | Alco Electronic Products                                  | Lawrence, Mass.        |
| AMP         | 02660                | Amphenol Borg Electronics                                 | Broadview, Ill.        |
| AM          | 00779                | AMP Inc.  | Philadelphia, Pa.      |
| AR          | 04062                | Arco Electronics, Inc.                                    | Great Neck, N.Y.       |
| BE          | 70903                | Belden Mfg. Company                                       | Chicago, Ill.          |
| BK          | 73138                | Beckman Instruments Corp.                                 | Fullerton, Ca.         |
| BU          | 71400                | Bussman Mfg. Div of McGraw Co.                            | St. Louis, Mo.         |
| BY          | -                    | Buckeye Stamping Co.                                      | Columbus, Ohio         |
| CA          | -                    | Caddock Electronics Inc.                                  | Riverside, Ca.         |
| CM          | 71744                | Chicago Miniature Lamp Works Inc                          | Chicago, Ill.          |
| CE          | 71590                | Centralab Div of Globe-union                              | Milwaukee, Wisc.       |
| CD          | 14655                | Cornell-Dublier Electric Co.                              | Newark, N.J.           |
| CG          | 14674                | Corning Glass Works                                       | Corning, N.Y.          |
| CH          | 34423                | Clarke-Hess Comm. Res. Corp.                              | New York, N.Y.         |
| CL          | 12697                | Clarostate Mfg. Co.                                       | Dover, N.H.            |
| DA          | 91637                | Dale Electronics Inc.                                     | Columbus, Neb.         |
| ER          | 72982                | Erie Tech. Products Inc.                                  | Erie, Pa.              |
| EJ          | 74970                | E.F. Johnson Co.  | Waseca, Minn.          |
| FR          | 07263                | Fairchild Camera & Instr. Corp.<br>Semiconductor Division | Mountainview, Ca.      |
| GE          | 03508                | G.E. Semiconductor Prod. Div                              | Syracuse, N.Y.         |

| <u>Abb.</u> | <u>F.S.<br/>Code</u> | <u>Company Name</u>                        | <u>Company Address</u> |
|-------------|----------------------|--|------------------------|
| HP          | 28480                | Hewlett-Packard                            | Palo Alto, Ca.         |
| HH          | 83330                | Herman H. Smith Inc.                       | Manasquan, N.J.        |
| IR          | 18486                | TRW Electronic Components Div              | Des Plains, Ill.       |
| KE          | -                    | Kemet Capacitors Div<br>Union Carbide Corp | Greenville, S.C.       |
| MA          | 37942                | P. R. Mallory & Co., Inc.                  | Indianapolis, Ind.     |
| MO          | 04713                | Motorola Inc., Semiconductor Prod          | Phoenix, Ariz.         |
| NA          | 27014                | National Semiconductor Corp                | Santa Clara, Ca.       |
| OH          | 44655                | Ohmite Mfg. Co.                            | Skokie, Ill.           |
| RA          | 02735                | RCA Semiconductor Div                      | Sommerville, N.J.      |
| RN          | -                    | Robinson Nugent Inc.                       | New Albany, Ind.       |
| SC          | -                    | Schauer Mfg. Co.                           | Cincinnati, Ohio       |
| SI          | -                    | Signal Transformer Inc.                    | Inwood, N.Y.           |
| Sp          | 56289                | Sprague Electric Co.                       | North Adams, Mass.     |
| SW          | 82389                | Switchcraft inc.                           | Chicago, Ill.          |
| SY          | 93332                | Sylvania Electric Products, Inc.           | Woburn, Mass.          |
| TI          | 01295                | Texas Instruments, Transistor Prod         | Dallas, Texas          |
| TR          | 84411                | TRW Capacitor Division                     | Ogallala, Neb.         |
| UC          | 05397                | Union Carbide Corp., Elect. Div            | New York, N.Y.         |
| WK          | 05820                | Wakefield Engineering, Inc.                | Wakefield, Mass.       |

### 5-3. CHASSIS, CASE, CONNECTORS, AND MAJOR COMPONENTS

| <u>Circuit Ref.</u> | <u>Description</u>                                | <u>Mfr.*</u> | <u>Type or Part. No.</u> |
|---------------------|---|--------------|--------------------------|
|                     | Front Dress Panel                                 | CH           | CH-25507                 |
|                     | Rear Panel  | CH           | CH-25508                 |
|                     | Dummy Panel                                       | CH           | CH-25509                 |
|                     | Side Chassis                                      | CH           | CH-25510                 |
|                     | Cover (Top and Bottom)                            | CH           | CH-25511                 |
|                     | Voltage Box                                       | CH           | CH-25520                 |
|                     | Covers for Voltage Box                            | CH           | CH-25521                 |
|                     | Cover Plates                                      | CH           | CH-25522                 |
|                     | Main Printed Circuit Board                        | CH           | CH-25580                 |
|                     | Current Attenuator Board                          | CH           | CH-25581                 |
|                     | Voltage Attenuator Board                          | CH           | CH-25582                 |
|                     | Display Board                                     | CH           | CH-25583                 |
| SWI-4               | 4 Section DPDT Pushbutton Switch                  | CH           | CH-25590                 |
| SW5-7               | 3 Section DPDT Pushbutton Switch                  | CH           | CH-25591                 |
| SW200,<br>SW301     | Rotary Switch, ON/OFF and Function,<br>7 Position | CH           | CH-25592                 |
| J1                  | Connector Assembly, 0.156" Center<br>Spacing      | AM           | 583660-8                 |
|                     | 8 pin Socket                                      | RN           | ICY-083-S3               |
|                     | 14 Pin Socket                                     | RN           | ICY-143-S3               |

\*See Section 5-2 for key to abbreviations.

| <u>Circuit Ref.</u> | <u>Description</u>   | <u>Mfr.*</u> | <u>Type or Part No.</u> |
|---------------------|----------------------|--------------|-------------------------|
| X301                | Transformer          | SI           | DP241-5-16              |
| X303                | Transformer          | SI           | DP241-4-36              |
|                     | Line Cord            | BE           | 17250                   |
|                     | Line Cord Receptacle | SW           | EAC-301                 |
|                     | Knob                 | BK           | SS70-BL-2               |
|                     | Fuseholder           | BU           | HKP                     |
|                     | Fuse                 | BU           | AGC $\frac{1}{2}$       |
| T110,etc            | Input Terminals      | HH           | 1517                    |

5-4. VOLTAGE BOX CIRCUITRY PARTS LIST.

| <u>Circuit Ref.</u> | <u>Description<br/>Ohms/Tolerance/Power/Type **</u> | <u>Mfr.*</u> | <u>Type or Part No.</u> |
|---------------------|---|--------------|-------------------------|
| R130                | 5 Mohm, 1%, 1.25 W Resistor                         | CA           | ML218                   |
| R131,133            | 4990 ohm, 1%, $\frac{1}{4}$ W Resistor              | AB           | RN55D                   |
| R132                | 15.8 kohms, 1%, $\frac{1}{4}$ W Resistor            | AB           | RN55C                   |
| R134,5              | 100 ohms, 1%, $\frac{1}{4}$ W Resistor              | AB           | RN55D                   |
| R136                | 1500 ohms, 1%, $\frac{1}{4}$ W Resistor             | AB           | RN55D                   |
| R137                | 2000 ohms, 1%, $\frac{1}{4}$ W Resistor             | AB           | RN55C                   |
| R138,140            | 845 ohms, 1%, $\frac{1}{4}$ W Resistor              | AB           | RN55C                   |

---

\*See Section 5-2 for key to abbreviations.

| <u>Circuit Ref.</u> | <u>Description</u>                      | <u>Mfr.*</u> | <u>Type or Part No.</u> |
|---------------------|---|--------------|-------------------------|
| R139                | 18.2 ohms, 1%, $\frac{1}{4}$ W Resistor | AB           | RN55C                   |
| R141                | 100 ohms, 1%, $\frac{1}{4}$ W Resistor  | AB           | RN55C                   |
| R152                | 100kohms, 1% $\frac{1}{4}$ W Resistor   | AB           | RN55C                   |
| R145                | 10kohms, 5%, $\frac{1}{4}$ W Resistor   | AB           | CD                      |
| C130                | 1.2 pF, Ceramic Capacitor               | SP           | 10TCC-V12               |
| C132                | 330pF, Mica, 5% Capacitor               | CD           | DM15-330J               |
| C133                | 8-40pF Variable Trimmer                 | ST           | 10S-TRIKO-22            |
| C135                | 10uF, 35V Tantalum Capacitor            | KE           | K10E35                  |
| C138                | 1uF, Polycarbonate Capacitor            | FD           | MPC-13 1.0              |
| Z130                | 4.7 V Zener Diode (5%)                  | MO           | 1N750A                  |
| Z131                | 5.6 V Zener Diode (5%)                  | MO           | 1N4734A                 |
| D130,131            | Silicon Diodes                          | SY           | 1N914B                  |
| P130                | 200 ohm, Cermet, Single Turn Pot.       | BK           | 72PMR-201               |
| P138,140            | 100 ohm, Cermet, Single Turn Pot.       | BK           | 72PMR-101               |
| Q130                | Field Effect Transistor                 | MO           | 2N5461                  |
| Q131,132,<br>134    | NPN Transistor                          | MO           | 2N3904                  |
| Q133                | PNP Transistor                          | MO           | 2N3906                  |
| IC131               | Quad CMOS Switch                        | RA           | CD4016                  |
| IC132               | Quad CMOS Driver                        | RA           | CD4054                  |

#### 5-5. CURRENT ATTENUATOR PARTS LIST

|      |  |    |        |
|------|--|----|--------|
| R110 | 20 milliohm, 10W, 1% Resistor            | DA | RH10   |
| R111 | 200 milliohm, 200 milliwatt, 1% Resistor | DA | WWA-24 |

\*See Section 5-2 for key to abbreviations.



| <u>Circuit Ref.</u> | <u>Description</u>  | <u>Mfr.*</u> | <u>Type or Part No.</u> |
|---------------------|---|--------------|-------------------------|
| R112a               | 2.0 ohm, 150 milliwatt, 1% Resistor                         | DA           | WWA-23                  |
| R112b               | Range Trimmer Resistor                                      |              |                         |
| R113a               | 20 ohm, 1%, 1/4W Resistor                                   | AB           | RN55D                   |
| R113b               | Range Trimmer Resistor                                      |              |                         |
| R114                | 634 ohm, 1%, 1/4W Resistor                                  | AB           | RN55D                   |
| R115,119            | 499 ohm, 1%, 1/4W Resistor                                  | AB           | RN55D                   |
| R116                | Range Trimmer Resistor                                      |              |                         |
| R117                | 1000 ohm, 1%, 1/4W Resistor                                 | AB           | RN55D                   |
| R118                | 40.2 kohm, 1%, 1/4W Resistor                                | AB           | RN55D                   |
| R120                | 510 kohm, 5%, 1/4W Resistor                                 | AB           | CB                      |
| R121                | 150 kohm, 1%, 1/4W Resistor                                 | AB           | RN55D                   |
| R123                | 110 kohm, 1%, 1/4W Resistor                                 | AB           | RN55D                   |
| C115                | 240pF, Mica, 5% Capacitor                                   | CD           | DM15-241J               |
| C116                | 1200pF, Mica, 5% Capacitor                                  | CD           | CM06-122J               |
| C117                | 5pF (nominal) 5mA Phase Trimmer                             |              |                         |
| C118                | 130pF, Mica, 5% Capacitor                                   | CD           | DM15-131J               |
| C119                | 220pF, Mica, 5% Capacitor                                   | CD           | DM15-221J               |
| C120                | 240pF, Mica, 5% Capacitor                                   | CD           | DM15-241J               |
| C121                | 33pF, Mica, 5% Capacitor                                    | CD           | DM15-330J               |
| C122                | 1800pF, Mica, 5% Capacitor                                  | CD           | DM15-182J               |
| C123                | 7pF, Mica, 5% Capacitor                                     | CD           | DM15-070J               |
| P114                | 200 ohm, Single Turn Cermet Trimmer                         | BK           | 72PMR-201               |
| P115,119            | 500 ohm, Single Turn Cermet Trimmer                         | BK           | 72PMR-501               |
| D110-113            | Voltage Limiting Diodes                                     | TI           | 1N4004                  |
| F110                | 1-1/2 Amp Fast Acting Fuse<br>Fuse Clips (2 each) 1/4" dia. | BU<br>LI     | AGX 1-1/2<br>102060     |

#### 5-6. ANALOG SECTION PARTS LIST

| <u>Circuit Ref.</u> | <u>Resistors</u>                   |  |  |  | <u>Mfr.*</u> | <u>Type or Part No.</u> |
|---------------------|------------------------------------|--|--|--|--------------|-------------------------|
|                     | <u>Ohms/Tolerance/Power/Type**</u> |  |  |  |              |                         |
| R3,11               | 2 M 1% 1/4W MF                     |  |  |  | AB           | RN55D                   |
| R4                  | 2150 1% 1/4W MF                    |  |  |  | AB           | RN55D                   |

\*See Section 5-2 for key to abbreviations.

#Nominal values. in some cases the component may not be present.

| Circuit Ref. | Description |           |                 |        | Mfr.* | Type or Part No. |
|--------------|-------------|-----------|-----------------|--------|-------|------------------|
|              | Ohms        | Tolerance | Power           | Type** |       |                  |
| R5,8         | 1000        | 1%        | $\frac{1}{4}$ W | MF     | AB    | RN55D            |
| R6           | 1330        | 1%        | $\frac{1}{4}$ W | MF     | AB    | RN55D            |
| R7           | 6490        | 1%        | $\frac{1}{4}$ W | MF     | AB    | RN55D            |
| R9           | 2150        | 1%        | $\frac{1}{4}$ W | MF     | AB    | RN55D            |
| R10          | 4990        | 1%        | $\frac{1}{4}$ W | MF     | AB    | RN55D            |
| R12          | 2000        | 1%        | $\frac{1}{4}$ W | MF     | AB    | RN55D            |
| R13,24       | 10,000      | 1%        | $\frac{1}{4}$ W | MF     | AB    | RN55D            |
| R14          | 1330        | 1%        | $\frac{1}{4}$ W | MF     | AB    | RN55D            |
| R15,28       | 1000        | 5%        | $\frac{1}{4}$ W | CC     | AB    | CB               |
| R16,23       | 1000        | 1%        | $\frac{1}{4}$ W | MF     | AB    | RN55D            |
| R17,26       | 3320        | 1%        | $\frac{1}{4}$ W | MF     | AB    | RN55D            |
| R18,30       | 499         | 1%        | $\frac{1}{4}$ W | MF     | AB    | RN55D            |
| R19          | 80,600      | 1%        | $\frac{1}{4}$ W | MF     | AB    | RN55D            |
| R20,22       | 27,000      | 5%        | $\frac{1}{4}$ W | CC     | AB    | CB               |
| R21,27       | 2700        | 5%        | $\frac{1}{4}$ W | CC     | AB    | CB               |
| R25          | 1820        | 1%        | $\frac{1}{4}$ W | MF     | AB    | RN55D            |
| R29          | 40,200      | 1%        | $\frac{1}{4}$ W | MF     | AB    | RN55D            |
| R31          | 4020        | 1%        | $\frac{1}{4}$ W | MF     | AB    | RN55D            |
| R32          | 10,000      | 1%        | $\frac{1}{4}$ W | MF     | AB    | RN55D            |
| R33          | 53,600      | 1%        | $\frac{1}{4}$ W | MF     | AB    | RN55D            |
| R34          | 19,100      | 1%        | $\frac{1}{4}$ W | MF     | AB    | RN55D            |
| R35,36       |             |           |                 |        |       |                  |
| 37,38        | 3320        | 1%        | $\frac{1}{4}$ W | MF     | AB    | RN55D            |
| R39          | 2150        | 1%        | $\frac{1}{4}$ W | MF     | AB    | RN55D            |
| R40          | 3010        | 1%        | $\frac{1}{4}$ W | MF     | AB    | RN55D            |
| R41,42       | 3320        | 1%        | $\frac{1}{4}$ W | MF     | AB    | RN55D            |
| R43,45       | 53,600      | 1%        | $\frac{1}{4}$ W | MF     | AB    | RN55D            |
| R44,46       | 499         | 1%        | $\frac{1}{4}$ W | MF     | AB    | RN55D            |
| R47,48       | 40,200      | 1%        | $\frac{1}{4}$ W | MF     | AB    | RN55D            |
| R49          | 200         | 1%        | $\frac{1}{4}$ W | MF     | AB    | RN55D            |
| R50          | 121K        | 1%        | $\frac{1}{4}$ W | MF     | AB    | RN55D            |
| R51          | 316         | 1%        | $\frac{1}{4}$ W | MF     | AB    | RN55D            |
| R52,53       | 5760        | 1%        | $\frac{1}{4}$ W | MF     | AB    | RN55D            |
| R54,55       | 10,000      | 5%        | $\frac{1}{4}$ W | CC     | AB    | CB               |
| R56          | 49,900      | 1%        | $\frac{1}{4}$ W | MF     | AB    | RN55D            |
| R57          | 9310        | 1%        | $\frac{1}{4}$ W | MF     | AB    | RN55D            |
| R58          | 88,700      | 1%        | $\frac{1}{4}$ W | MF     | AB    | RN55D            |
| R59          | 1 M         | 5%        | $\frac{1}{4}$ W | CC     | AB    | CB               |
| R60          | 750         | 1%        | $\frac{1}{4}$ W | MF     | AB    | RN55D            |
| R61          | 22,100      | 1%        | $\frac{1}{4}$ W | MF     | AB    | RN55D            |

\* See Section 5-2 for key to abbreviations.  
MF under TYPE means Metal Film, while CC means Carbon.

| Circuit Ref. | Description                              |    |                 |    | Mfr. | Type or Part No. |  |
|--------------|--|----|-----------------|----|------|------------------|--|
|              | Ohms/Tolerance/Power/Type                |    |                 |    |      |                  |  |
| R62          | 47,000                                   | 5% | $\frac{1}{4}$ W | CC | AB   | CB               |  |
| R63,64       | 1000                                     | 1% | $\frac{1}{4}$ W | MF | AB   | RN55D            |  |
| R65          | 150,000                                  | 1% | $\frac{1}{4}$ W | MF | AB   | RN55D            |  |
| R67,72       | 100,000                                  | 1% | $\frac{1}{4}$ W | MF | AB   | RN55D            |  |
| R68          | 150,000                                  | 1% | $\frac{1}{4}$ W | MF | AB   | RN55D            |  |
| R69          | 49,900                                   | 1% | $\frac{1}{4}$ W | MF | AB   | RN55D            |  |
| R70          | 34,000                                   | 1% | $\frac{1}{4}$ W | MF | AB   | RN55D            |  |
| R71          | 200,000                                  | 1% | $\frac{1}{4}$ W | MF | AB   | RN55D            |  |
| R73          | Square Root (1/10) Full Scale Adjustment |    |                 |    |      |                  |  |
| R75          | 10,000                                   | 1% | $\frac{1}{4}$ W | MF | AB   | RN55D            |  |
| R76          | Square Root Compensation                 |    |                 |    |      |                  |  |
| R77          | 1 M                                      | 5% | $\frac{1}{4}$ W | CC | AB   | CB               |  |
| R78          | 100,000                                  | 5% | $\frac{1}{4}$ W | CC | AB   | CB               |  |
| R79          | 5760                                     | 1% | $\frac{1}{4}$ W | MF | AB   | RN55D            |  |
| R80          | 510                                      | 5% | $\frac{1}{4}$ W | CC | AB   | CB               |  |
| R81          | 1000                                     | 5% | $\frac{1}{4}$ W | CC | AB   | CB               |  |
| R82          | 499                                      | 1% | $\frac{1}{4}$ W | MF | AB   | RN55D            |  |
| R83          | 7870                                     | 1% | $\frac{1}{4}$ W | MF | AB   | RN55D            |  |
| R84#         | 18,000                                   | 5% | $\frac{1}{4}$ W | CC | AB   | CB               |  |
| R85          | 750                                      | 1% | $\frac{1}{4}$ W | MF | AB   | RN55D            |  |
| R92#         | 360,000                                  | 5% | $\frac{1}{4}$ W | CC | AB   | CB               |  |
| R93          | 100,000                                  | 1% | $\frac{1}{4}$ W | MF | AB   | RN55D            |  |
| R94          | 732,000                                  | 1% | $\frac{1}{4}$ W | MF | AB   | RN55D            |  |
| R95#         | 100,000                                  | 1% | $\frac{1}{4}$ W | MF | AB   | RN55D            |  |
| R98#         | 270,000                                  | 5% | $\frac{1}{4}$ W | MF | AB   | RN55D            |  |
| R99          | 3,010                                    | 1% | $\frac{1}{4}$ W | MF | AB   | RN55D            |  |

Capacitors

| Circuit Ref. | Description |        |      | Mfr. | Type or Part No. |
|--------------|-------------|--------|------|------|------------------|
|              |             |        |      |      |                  |
| C1,11        | Disc        | .05uF  | 100V | CE   | UK25-503         |
| C3,4,7,9     | Mica        | 120pF  | 5%   | AR   | DM15121J         |
| C8           | Disc        | 0.1uF  | 25V  | CE   | UK-25-104        |
| C6,10,11     | Mica        | 22pF   | 10%  | AR   | DM15220J         |
| C12          | Film        | 1uF    | 100V | FD   | MPC13 1.0        |
| C13          | Mica        | 22pF   | 5%   | AR   | DM15220J         |
| C14          | Mica        | 56pF   | 5%   | AR   | DM15560J         |
| C15          | Mica        | 120pF  | 5%   | AR   | DM15121J         |
| C16          | Film        | 1uF    | 100V | FD   | MPC13 1.0        |
| C18          | Disc        | 1000pF | 5%   | SP   | Type DD          |
| C19          | Disc        | 470pF  | 5%   | CE   | Type DD          |
| C20          | Disc        | 0.01uF | 100V | SP   | TG-S10           |
| C21          | Tantalum    | 1uF    | 25V  | KE   | K1E25            |

#Value shown is a nominal value. Component is used for "trimming" or "compensation". In some cases the component may not be present.

| <u>Circuit Ref.</u>   |          | <u>Description</u> |      | <u>Mfr.</u> | <u>Type or Part No</u> |
|-----------------------|----------|--------------------|------|-------------|------------------------|
| C22                   | Mica     | 200pF              | 5%   | AR          | DM15-201J              |
| C23A24,27<br>28,29,30 | Tantalum | 10uF               | 25V  | KE          | K10E25                 |
| C26                   | Mica     | 39pF               | 5%   | AR          | DM15-390J              |
| C39#                  | Mica     | 18pF               | 100V | AR          | DM15-180J              |
| C42                   | Disc     | 0.1uF              | 25V  | CE          | UK24-104               |
| C44#                  | Disc     | 0.01uF             | 25V  | CE          | UK25-103               |
| C51                   | Trimmer  | 3-12pF             |      | EJ          | 275-0012-005           |
| C53                   | Mica     | 56pF               |      | AR          | DM15-560J              |
| C54,55                | Mica     | 39pF               |      | AR          | DM15-390J              |
| C56,57                | Mica     | 5pF                | 100V | AR          | DM15-050J              |
| C61,62                | Mica     | 15pF               |      | AR          | DM15-220J              |
| C63,64                | Mica     | 22pF               |      | AR          | DM15-100J              |
| C84#                  | Disc     | 1000pF             | 25V  | CE          | UK25-102               |
| C92,94#               | Mica     | 18pF               | 100V | AR          | DM15-180J              |
| C93,95#               | Mica     | 7pF                | 100V | AR          | DM15-070J              |
| C98#                  | Mica     | 2pF                | 100V | AR          | DM5-020J               |

#### Integrated Circuits

| <u>Circuit Ref.</u> | <u>Description</u>              | <u>Mfr.</u> | <u>Type or Part No.</u> |
|---------------------|---------------------------------|-------------|-------------------------|
| IC1,2,3,4           | FET Input Operational Amplifier | RA          | CA3130S                 |
| IC21,30             | FET Input Operational Amplifier | RA          | CA3130S                 |
| IC5,6               | Dual Comparator                 | FA          | u711HC                  |
| IC7                 | Multiplier                      | MO          | MC1595                  |
| IC11,12,13          | Quad FET Switches               | RA          | CD4016AE                |
| IC20                | Dual Operational Amplifier      | NA          | LM1458N                 |
| IC31                | Comparator                      | NA          | LM311N                  |

#### Transistors and Diodes.

|                         |                        |    |        |
|-------------------------|------------------------|----|--------|
| Q1,2,8,9,12<br>16,17,18 | NPN Silicon Transistor | NA | 2N3904 |
| Q3,4,5,6,7,<br>11,13,15 | PNP Silicon Transistor | NA | 2N3906 |
| Q14                     | N Channel FET          | TI | 2N3819 |
| D5,6,7                  | High Speed Diode       | TI | 1N914B |
| D11-14                  | Protection Diodes      | TI | 1N4004 |
| D64,65,84 #             | Compensation Diodes    | TI | 1N914B |

# Value shown is a nominal value. Component is used for "trimming" or "compensation". In some cases the component may not be present.

5-7. POTENTIOMETERS - MAIN BOARD(P119, P139 listed in 5-5, 5-4)

| <u>Circuit Ref.</u> | <u>Description</u>                      | <u>Mfr.*</u> | <u>Type or Part No.</u> |
|---------------------|---|--------------|-------------------------|
| P1                  | 200 ohms Single Turn, Cermet Trimmer    | BK           | 72PMR200                |
| P2,12               | 100,000 ohms Twenty Turn Trimmer        | AB           | MT-2W-104               |
| P20,28              | 25,000 ohms Single Turn Cermet Trimmer  | BK           | 72PMR25K                |
| P44,46,<br>49       | 100,000 ohms Twenty Turn Trimmer        | AB           | MT-2W-104               |
| P63                 | 100,000 ohms Single Turn Cermet Trimmer | BK           | 72PMR100K               |
| P58                 | 1000 ohms Single Turn Cermet Trimmer    | BK           | 72PMR1K                 |
| P61                 | 5000 ohms Single Turn Cermet Trimmer    | BK           | 72PMR5K                 |
| P66                 | 25,000 ohms Single Turn Cermet Trimmer  | BK           | 72PMR25K                |
| P74                 | 100 ohms Single Turn Cermet Trimmer     | BK           | 72PMR101                |
| P84                 | 200 ohms Twenty Turn Cermet Trimmer     | AB           | MT2W-201                |
| P252                | 100,000 ohms Single Turn Cermet Trimmer | BK           | 72PMR100K               |
| P253                | 250,000 ohms Single Turn Cermet Trimmer | BK           | 72PMR250K               |

5-8. DIGITAL SECTION PARTS LIST

Resistors

All resistors in this section have the following characteristics unless otherwise specified. Tolerance - 5%; Power - 1/4W; Carbon Composition Manufactured by Allen-Bradley Corp.

| <u>Circuit Ref.</u>            | <u>Description</u><br><u>Ohms/Tolerance/Power/Type **</u> | <u>Mfr.*</u> | <u>Type or Part No.</u> |
|--------------------------------|---|--------------|-------------------------|
| R201, 202,<br>203, 204,<br>205 | 10,000  |              |                         |

\* See Section 5-2 for key to abbreviations.

| <u>Circuit Ref.</u>            | <u>Description</u>                 |    |                 |    | <u>Mfr.*</u> | <u>Type or Part No.</u> |
|--------------------------------|------------------------------------|----|-----------------|----|--------------|-------------------------|
|                                | <u>Ohms/Tolerance/Power/Type**</u> |    |                 |    |              |                         |
| R214                           | 3300                               |    |                 |    |              |                         |
| R215                           | 5600                               |    |                 |    |              |                         |
| R218                           | 1910                               | 1% | $\frac{1}{4}$ W | MF | AB           | RN55D                   |
| R220, 221,<br>222, 223,<br>224 | 10,000                             |    |                 |    |              |                         |
| R226, 228                      | 6800                               |    |                 |    |              |                         |
| R227, 229                      | 11,000                             |    |                 |    |              |                         |
| R231, 232<br>233               | 10,000                             |    |                 |    |              |                         |
| R234, 236                      | 27,000                             |    |                 |    |              |                         |
| R235, 237<br>238, 240          | 10,000                             |    |                 |    |              |                         |
| R241, 242                      | 510                                |    |                 |    |              |                         |
| R246                           | 6800                               |    |                 |    |              |                         |
| R247                           | 11,000                             |    |                 |    |              |                         |
| R250                           | 47,000                             |    |                 |    |              |                         |
| R251                           | 665,000                            | 1% | $\frac{1}{4}$ W | MF | AB           | RN55D                   |
| R252                           | 121,000                            | 1% | $\frac{1}{4}$ W | MF | AB           | RN55D                   |
| R253                           | 221,000                            | 1% | $\frac{1}{4}$ W | MF | AB           | RN55D                   |
| R260                           | 39,000                             |    |                 |    |              |                         |
| R261                           | 3300                               |    |                 |    |              |                         |
| R288, 289                      | 5600                               |    |                 |    |              |                         |

\*See Section 5-2 for key to abbreviations.

\*\* MF under Type means Metal Film.

Diodes, Transistors, Capacitors

| <u>Circuit Ref.</u> | <u>Description</u>           | <u>Mfr.*</u> | <u>Type or Part No.</u> |
|---------------------|------------------------------|--------------|-------------------------|
| C215                | 120pF, 5%, Mica Capacitor    | AR           | DM15-121J               |
| C218                | 39pF, 5%, Mica Capacitor     | AR           | DM15-390J               |
| C219,230            | 0.1uF, 25V. Disc Capacitor   | CE           | UK25-104                |
| C234                | 10uF, 25V Tantalum Capacitor | KE           | K10E25                  |
| C239                | 0.01uF, 100V Disc Capacitor  | SP           | TS-S10                  |
| C240                | 0.1uF, 100V Disc Capacitor   | CE           | UK25-104                |
| C241,242            | 1000pF, 25V Disc Capacitor   | SP           | 125LD10                 |
| C246                | 91pF, 5%, Mica Capacitor     | AR           | DM5-910J                |
| C251                | 130pF, 5%, Mica Capacitor    | AR           | DM15-131J               |
| C252                | 0.1uF, 25V, Disc Capacitor   | CE           | UK25-104                |
| C253                | 1800pF, 5%, Mica Capacitor   | AR           | DM15-182J               |
| C261                | 1000pF, 25V, Disc Capacitor  | SP           | 125LD10                 |
| D207                | Germanium Diode              | TI           | 1N270                   |
| D201,202,261        | High Speed Diode             | TI           | 1N914B                  |
| Q219,220,222        | NPN Transistor               | NA           | 2N3904                  |
| Q221                | PNP Transistor               | NA           | 2N3906                  |

Integrated Circuits

|       |                      |    |           |
|-------|----------------------|----|-----------|
| IC200 | Triple, 3 Input NAND | FD | 9LS10     |
| IC201 | Quad, 2 Input NAND   | FD | 9LS00     |
| IC202 | 1024-bit PROM        | CH | CH-255202 |

---

\*See Section 5-2 for key to abbreviations.

| <u>Circuit Ref.</u>        | <u>Description</u>  | <u>Mfr.*</u> | <u>Type or Part No.</u> |
|----------------------------|---------------------|--------------|-------------------------|
| IC203                      | 1024-bit PROM       | CH           | CH-255203               |
| IC207,212                  | Quad, 2 Input AND   | RA           | CD4081AE                |
| IC211                      | Quad, 2 Input NAND  | FD           | 9LS00                   |
| IC214                      | Quad, 2 Input OR    | RA           | CD4071AE                |
| IC218                      | Hex Inverter        | RA           | CD4049AE                |
| IC219                      | Divide by N Counter | RA           | CD4018AE                |
| IC220                      | Dual Latch          | RA           | CD4013AE                |
| IC222                      | Quad, 2 Input AND   | RA           | CD4:81AE                |
| IC224                      | Divide by N Counter | RA           | CD4018AE                |
| IC225                      | Dual Latch          | RA           | CD4013AE                |
| IC226                      | Quad, 2 Input AND   | RA           | CD4081AE                |
| IC229,230                  | Hex Inverter        | RA           | CD4049Ae                |
| IC231,232<br>233,234       | Dual Latch          | RA           | CD4013AE                |
| IC238                      | Quad, 2 Input OR    | RA           | CD4071AE                |
| IC239                      | Quad, 2 Input AND   | RA           | CD4081AE                |
| IC240,241<br>242,243       | Display Driver      | RA           | CD4054AE                |
| IC250,251,<br>252,253,254, | Quad Switch         | RA           | CD4016AE                |

---

\*See Section 5-2 for key to abbreviations.



### 5-9. DISPLAY BOARD PARTS LIST

| <u>Circuit Ref.</u>          | <u>Description</u>                              | <u>Mfr.*</u> | <u>Type or Part No.</u> |
|------------------------------|---|--------------|-------------------------|
| IC401                        | Quad 2, Input open Collector NAND Gates         | TI           | SN74LS03                |
| IC402                        | Dual, 4 input NOR Gates                         | RA           | CD4002AE                |
| IC405,406,407,<br>408,       | Counter, BCD Latch, Seven Segment<br>Led Driver | TI           | SN74143N                |
| IC409,410,411,<br>412        | Seven Segment Display                           | HP           | 5082-7650               |
| Q400                         | NPN Silicon Transistor                          | NA           | 2N3904                  |
| D401                         | Germanium Diode                                 | TI           | 1N270                   |
| L420,421,422,<br>423         | Light-emitting Diodes                           | CM           | CM4-43B                 |
| R400                         | 39,000 ohm, 5%, $\frac{1}{4}$ W Resistor        | AB           | CB                      |
| R402,403,<br>406,407,<br>408 | 2700 ohm, 5-Resistor Network                    | CT           | 750-61-R2.7K            |
| R401<br>405                  | 2700 ohm, 5%, $\frac{1}{4}$ W Resistor          | AB           | CB                      |
| R409                         | 47,000 ohm, 5%, $\frac{1}{4}$ W Resistor        | AB           | CB                      |
| R420,421,422,<br>423         | 390 ohm, 5%, $\frac{1}{4}$ W Resistor           | AB           | CB                      |
| J2,3                         | 14 Pin Socket (with BCD Output Option)          | RN           | ICY-143-S3              |
| C401,<br>402                 | 470pF, Ceramic Disc Capacitor                   | CE           | DD                      |
| C403                         | 910pF, 5%, Mica Capacitor                       | AR           | DM15-911J               |
| C404                         | 1500pF, Ceramic Disc Capacitor                  | CE           | DD                      |

---

\*See Section 5-2 for key to abbreviations.

5-10. POWER SUPPLY PARTS LIST

| <u>Circuit Ref.</u>              | <u>Description</u>                                 | <u>Mfr.*</u> | <u>Type or Part No.</u> |
|----------------------------------|--|--------------|-------------------------|
| R301                             | 75 ohm, 5%, 3- $\frac{1}{4}$ W Wirewound Resistor  | OH           | 995-3A                  |
| R302                             | 130 ohm, 5%, 3- $\frac{1}{4}$ W Wirewound Resistor | OH           | 995-3A                  |
| R304                             | 4990 ohm, 1%, $\frac{1}{4}$ W Resistor             | AB           | RN55D                   |
| R307                             | 4750 ohm, 1% $\frac{1}{4}$ W, Resistor             | AB           | RN55D                   |
| R305                             | 634 ohm, 1%, $\frac{1}{4}$ W Resistor              | AB           | RN55D                   |
| R306                             | 3320 ohm, 1%, $\frac{1}{4}$ W Resistor             | AB           | RN55D                   |
| R308                             | 3740 ohm, 1%, $\frac{1}{4}$ W Resistor             | AB           | RN55D                   |
| R314                             | 7150 ohm, 1%, $\frac{1}{4}$ W Resistor             | AB           | RN55D                   |
| R315                             | 7320 ohm, 1%, $\frac{1}{4}$ W Resistor             | AB           | RN55D                   |
| R316                             | 3320 ohm, 1%, $\frac{1}{4}$ W Resistor             | AB           | RN55D                   |
| R317,318                         | 4990 ohm, 1%, $\frac{1}{4}$ W Resistor             | AB           | RN55D                   |
| D301,302,<br>303,304,<br>305,306 | Rectifier  | TI           | 1N4004                  |
| IC301                            | Voltage Regulator                                  | NA           | LM-340-5                |
| HS301                            | Heat Sink for IC301                                | WK           | 672-3B                  |
| IC303,<br>310                    | Voltage Regulator                                  | TI           | u723DIP                 |
| IC320                            | Dual Operational Amplifier                         | NA           | LM1458N                 |
| Q304,311                         | PNP Transistor                                     | MO           | 2N2905A                 |

---

\* See Section 5-2 for key to abbreviations.

| <u>Circuit Ref.</u>              | <u>Description</u>                   | <u>Mfr.*</u> | <u>Type or Part No.</u> |
|----------------------------------|--------------------------------------|--------------|-------------------------|
| Z301                             | 11 V 2%, 1W Zener Diode              | SC           | 11-2%                   |
| Z302                             | 9.1 V, 2%, 1W Zener Diode            | SC           | 9.1-2%                  |
| C300                             | 0.01uF, 100 V, Disc Capacitor        | SP           | TG-S10                  |
| C301a,<br>301b                   | 220uF, 10 V, Electrolytic Capacitor  | SP           | EV-1180                 |
| C302                             | 22uF, 25 V, Tantalum Capacitor       | KE           | K22E25                  |
| C303,304                         | 1000uF, 25 V, Electrolytic Capacitor | SP           | EV-1360                 |
| C307,308,<br>317,318,<br>320,321 | 10uF, 25 V, Tantalum Capacitor       | KE           | K10E25                  |
| C305,315                         | 1000pF, 25 V, Disc Capacitor         | CE           | DD-102                  |
| C306,310,<br>316                 | 0.1uF, 25 V, Disc Capacitor          | CD           | UK25-104                |

---

\*See Section 5-2 for key to abbreviations.



## VI. DIAGRAMS

### List of Drawings

- Drawing 25509 - Location Diagram - Current Attenuator Board
- Drawing 25510 - Schematic Diagram - Current Attenuator Board
- Drawing 25511 - Location Diagram - Voltage Attenuator Box
- Drawing 25512 - Schematic Diagram - Voltage Attenuator Box
- Drawing 25514 - Schematic Diagram - Analog Section
- Drawing 25515 - Location Diagram - Main Printed Circuit Board
- Drawing 25516 - Schematic Diagram - Digital Section
- Drawing 25518 - Schematic Diagram - Power Supplies
- Drawing 25519 - Location Diagram - Display Board
- Drawing 25520 - Schematic Diagram - Display Board

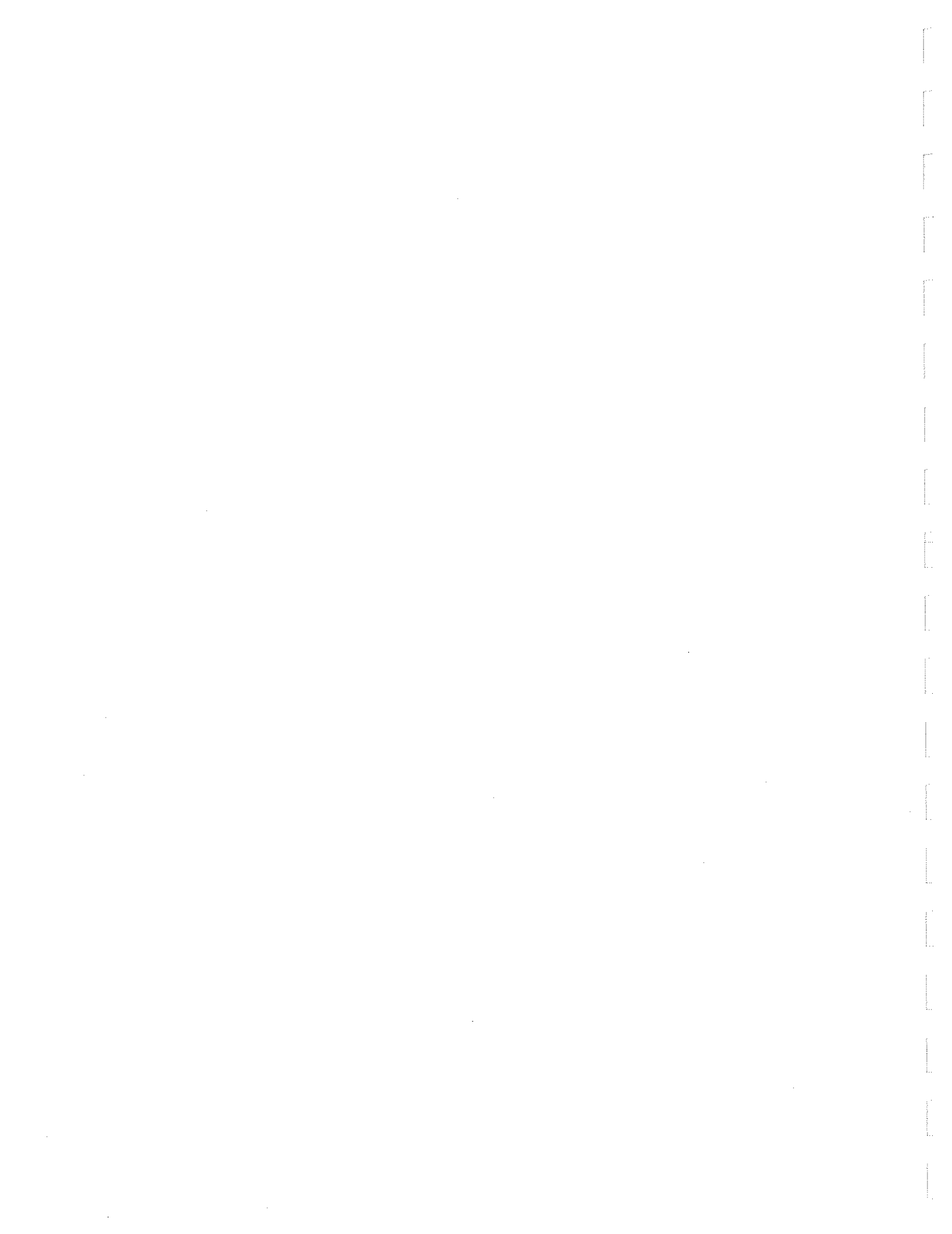

NOTE

A modification has been made to the wiring involving IC-1, IC-2, and IC-13 that is NOT shown on the ANALOG Schematic Drawing.

Pin 8 of IC-1 has been connected to Pin 8 of IC-13.

Pin 8 of IC-2 has been connected to Pin 11 of IC-13.

Pins 7, 9, and 10 of IC-13 have been connected together.  
(-6 V on all three pins.)

Pins 5 and 6 of IC-13 have been connected.

Pins 12 and 13 of IC-13 have been connected together.

The effect of these changes is to turn off IC-1 when VOLTAGE is being measured and to turn off IC-2 when CURRENT is being measured. Turning off the unused channel reduces the the possibility of high frequency "cross-talk" between the current and voltage channels.

When the CA 3130 operational amplifier ( IC-1 or IC-2 ) is turned off by returning Pin 8 to the negative supply voltage then the amplifier output comes to rest about one volt below the positive supply voltage. This means that if one measures the output of IC-1 with the FUNCTION switch on VOLTAGE the expected voltage will be about + 6.8 V. If the FUNCTION switch is moved to the CURRENT position this output DC voltage (assuming that no input is being supplied to the CURRENT terminals ) should drop to below 0.3 millivolts. If CURRENT and VOLTAGE are reversed then the same results will be obtained for IC-2

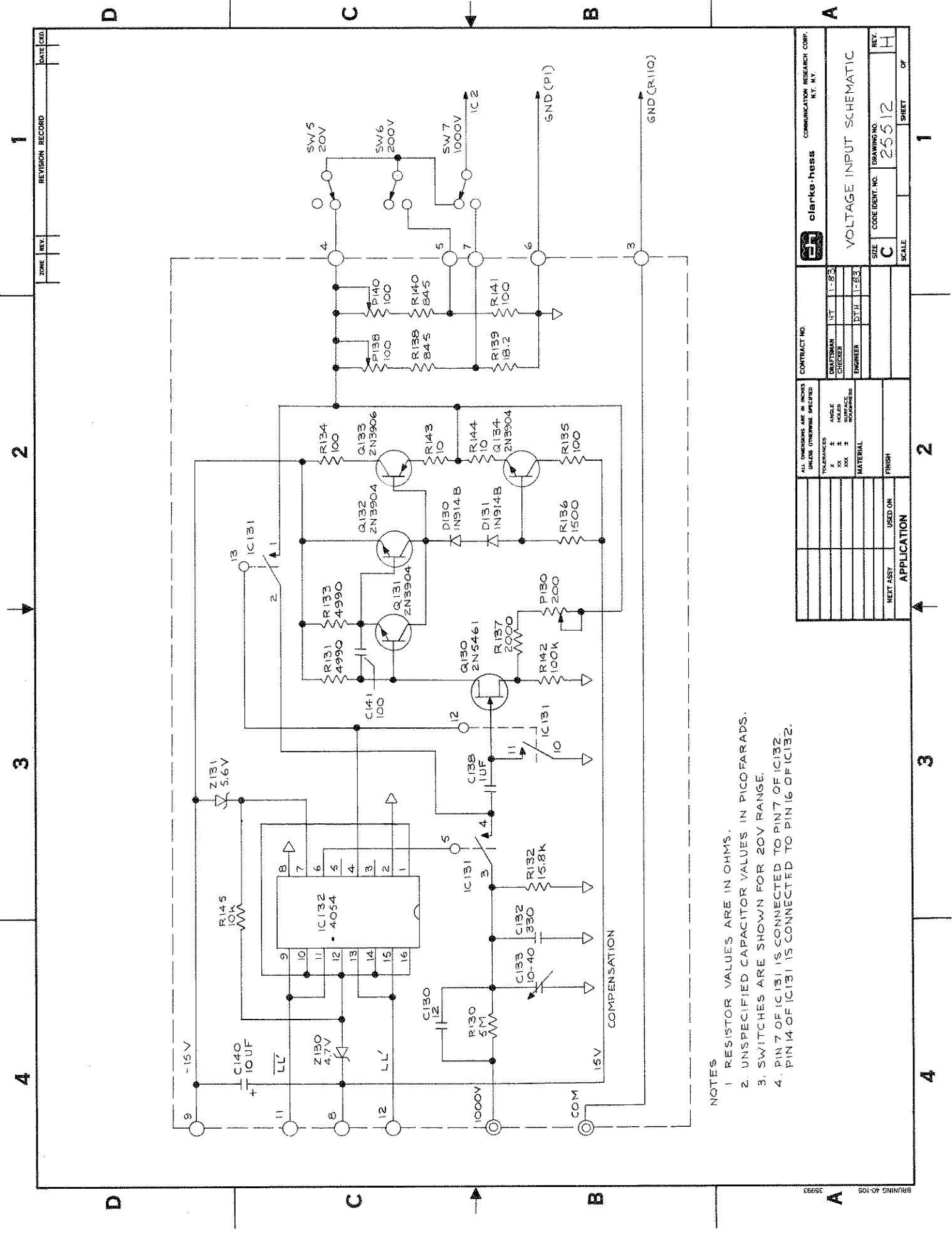

- NOTES
1. RESISTOR VALUES ARE IN OHMS.
  2. UNSPECIFIED CAPACITOR VALUES IN PICOFARADS.
  3. SWITCHES ARE SHOWN FOR 20V RANGE.
  4. PIN 7 OF IC131 IS CONNECTED TO PIN 7 OF IC132. PIN 14 OF IC131 IS CONNECTED TO PIN 16 OF IC132.

|   |       |
|---|-------|
| CLARKE-HESSE COMMUNICATION RESEARCH CORP. N.Y. N.Y. |       |
| CONTRACT NO.  |       |
| DRAFTSMAN   | LT    |
| CHECKER   | LT    |
| ENGINEER  | DTJ   |
| SIZE  | C     |
| CODE IDENT. NO.                                     | 25512 |
| DRAWING NO.   | 25512 |
| REV.  | H     |
| SCALE   |       |
| SHEET   | 1     |
| OF  |       |

|   |         |
|---|---------|
| ALL DIMENSIONS ARE IN INCHES UNLESS OTHERWISE SPECIFIED |         |
| TOLERANCES  |         |
| ANGLE   | ±       |
| HOLE DIA.   | ±       |
| SURFACE   | ±       |
| HOLES   | ±       |
| MATERIAL  |         |
| FINISH  |         |
| REPT ASST.  | USED ON |
| APPLICATION   |         |





4 3 2 1

|      |      |                 |
|------|------|-----------------|
| DATE | REV. | REVISION RECORD |
|      |      |                 |
|      |      |                 |

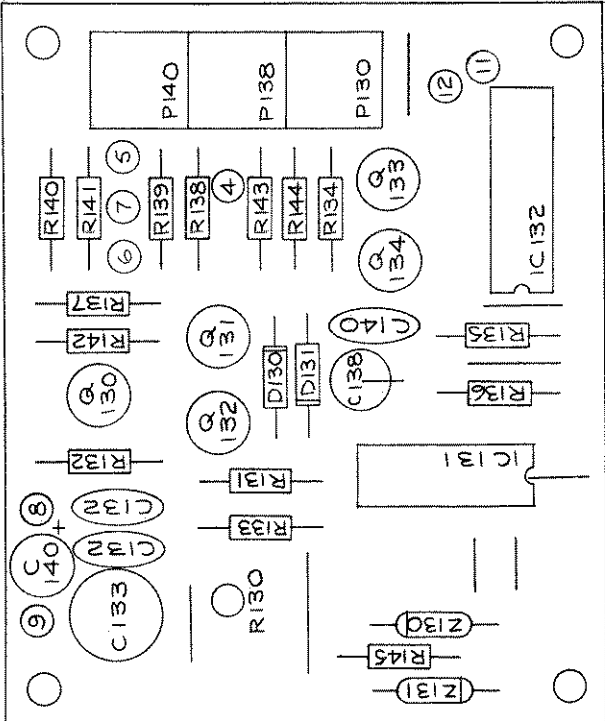

B

A

B

A

|   |                       |
|---|-----------------------|
| clarke-hess COMMUNICATION RESEARCH CORP. N.Y. N.Y.      |                       |
| CONTRACT NO.  |                       |
| CONTRACT NO.  | DATE                  |
| CHECKED BY  | DATE                  |
| ENGINEER  | DATE                  |
| ALL DIMENSIONS ARE IN INCHES UNLESS OTHERWISE SPECIFIED | TOLERANCES            |
| X ± .005  | ANGLES                |
| XX ± .010   | SURFACE               |
| XXX ± .015  | FINISH                |
| MATERIAL  | USED ON               |
| NEXT ASSEMBLY   | APPLICATION           |
| SIZE B  | CODE IDENT. NO. 25511 |
| SCALE   | DRAWING NO. 25511     |
| SHEET 1   | OF 1                  |



| ZONE | REV | REVISION RECORD        | DATE DOC |
|------|-----|------------------------|----------|
| C3   | C   | ADD C118 & R118        | 1/29/54  |
| D1   | D   | ADD C120 & R120        | 11/21/54 |
| E    | E   | REWIRE SWITCHES        | 8/60/57  |
| F    | F   | DELETE FUNCTION SWITCH | 1/23/58  |

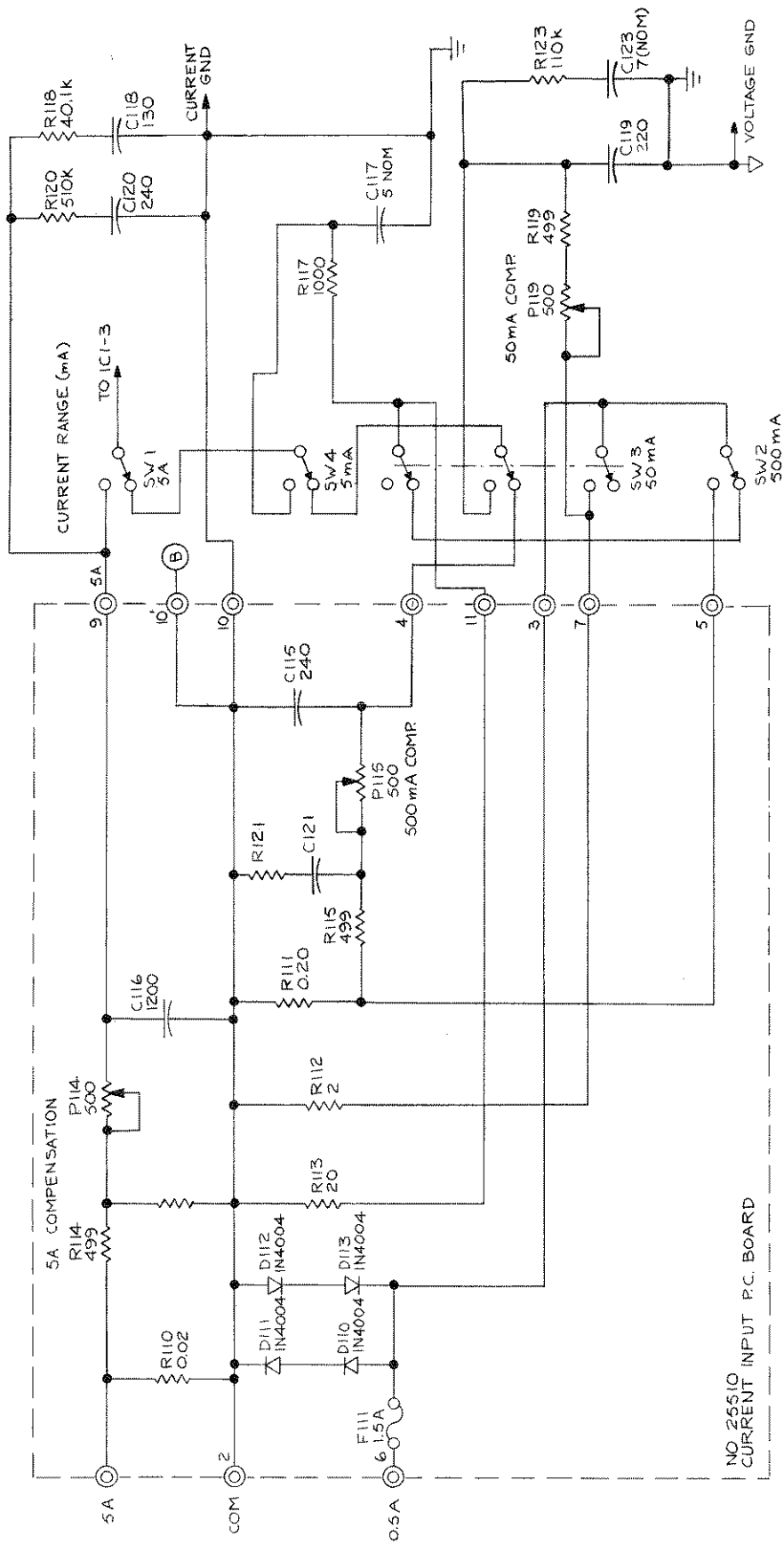

NO 25510  
CURRENT INPUT P.C. BOARD

- NOTES:  
 1 RESISTOR VALUES ARE IN OHMS  
 2 UNSPECIFIED CAPACITOR VALUES IN PICO FARADS  
 3 SWITCHES ARE SHOWN DEACTIVATED (OUT)

|  |   |                       |
|--|---|-----------------------|
| clark-hess COMMUNICATION RESEARCH CORP.<br>INC. N.Y.       |   | CONTRACT NO.<br>72725 |
| DRAWING NO.<br>25510                                       | CODE IDENT. NO.<br>25510  | REV.<br>E             |
| SIZE<br>C  | SCALE   | SHEET<br>1            |
| CURRENT INPUT SCHEMATIC DIAGRAM                            |   |                       |
| ALL DIMENSIONS ARE IN INCHES<br>UNLESS OTHERWISE SPECIFIED | TOLERANCES<br>FRACTIONS<br>DECIMALS<br>ANGLES<br>HOLE<br>DIA.<br>POSITIVE<br>NEGATIVE | MATERIAL<br>FINISH    |
| NEXT ASST<br>USED ON                                       | APPLICATION   | CASE                  |



1

2

3

4

B

A

B

A

|      |      |                 |           |
|------|------|-----------------|-----------|
| ZONE | REV. | REVISION RECORD | DATE (DD) |
|      |      |                 |           |

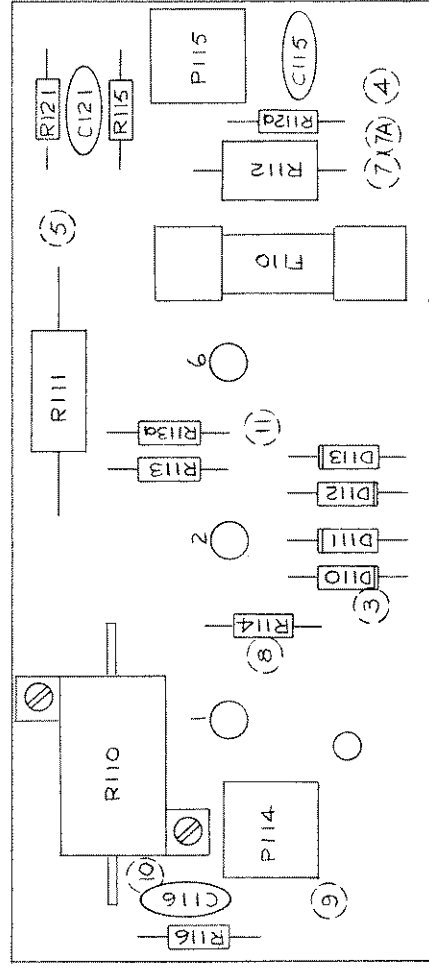

|   |   |                   |
|---|---|-------------------|
| clarke-hess COMMUNICATION RESEARCH CORP. N.Y. N.Y.      |   | CONTRACT NO.      |
| ALL DIMENSIONS ARE IN INCHES UNLESS OTHERWISE SPECIFIED |   | CONTRACT NO.      |
| TOLERANCES  | HOLE ±<br>XX ±<br>HOLE ±<br>SURFACE ±<br>FINISH ± | CONTRACT NO.      |
| MATERIAL  |   | CONTRACT NO.      |
| FINISH  |   | CONTRACT NO.      |
| APPLICATION   |   | CONTRACT NO.      |
| NEXT ASSY USED ON                                       |   | CONTRACT NO.      |
| SIZE B SCALE  |   | DRAWING NO. 25509 |
| REV. C  |   | SHEET 1 OF 1      |

1

2

3

4

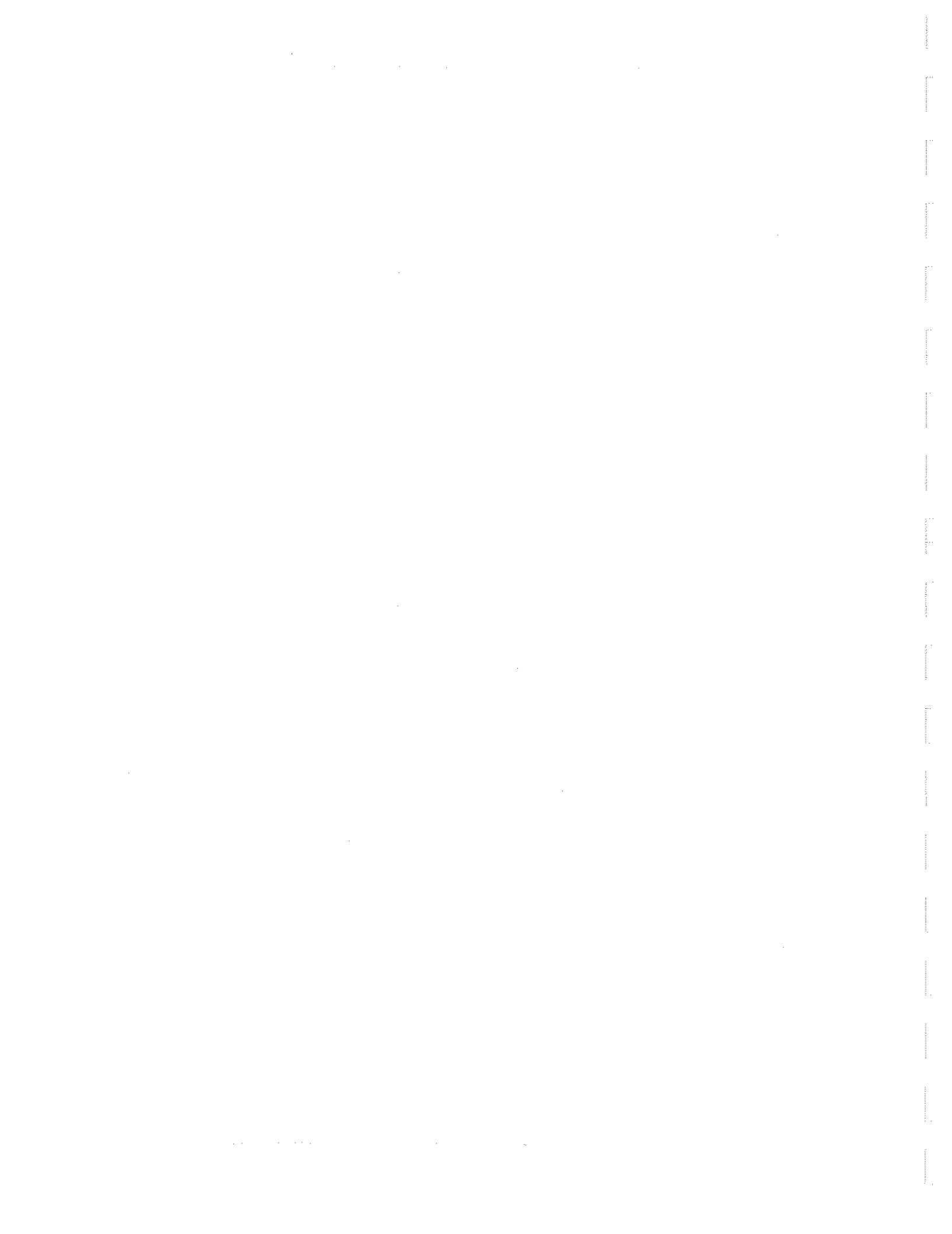

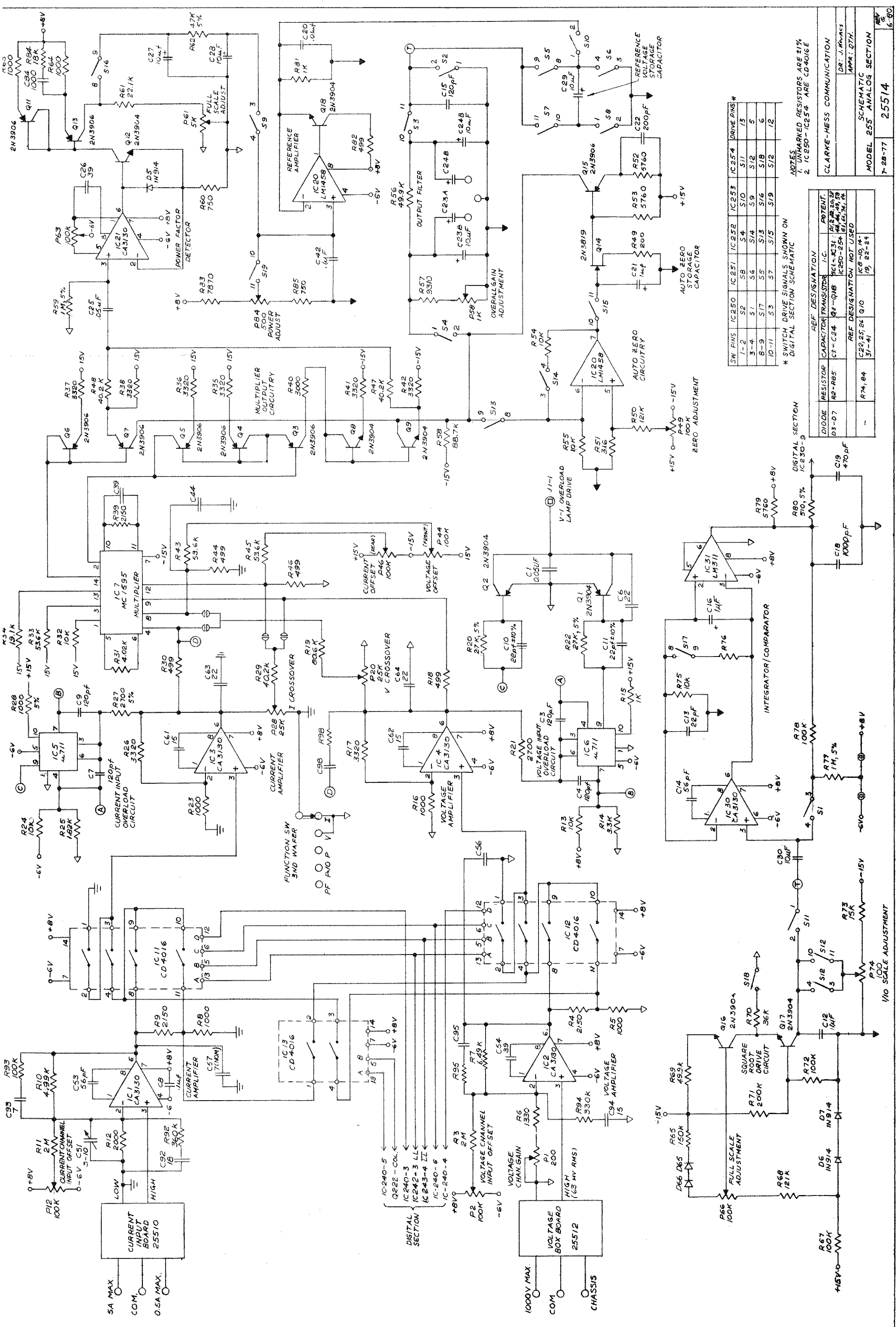

\* SWITCH DRIVE SIGNALS SHOWN ON DIGITAL SECTION SCHEMATIC

| SW PINS | IC 250 | IC 251 | IC 252 | IC 253 | IC 254 | DRIVE PINS* |
|---------|--------|--------|--------|--------|--------|-------------|
| 1-2     | S2     | S8     | S4     | S10    | S11    | 13          |
| 3-4     | S1     | S6     | S14    | S9     | S12    | 5           |
| 8-9     | S17    | S5     | S13    | S16    | S18    | 6           |
| 10-11   | S3     | S7     | S15    | S19    | S12    | 12          |

REF DESIGNATION

| DIODE | RESISTOR | CAPACITOR   | TRANSISTOR | I.C.                 | POTENT.   |
|-------|----------|-------------|------------|----------------------|---|
| D3-D7 | R1-R85   | C1-C24      | Q1-Q18     | IC1-IC31             | A1, B, C, D, E, F, G, H, I, J, K, L, M, N, O, P, Q, R, S, T, U, V, W, X, Y, Z |
| -     | R74, 84  | C25, 25, 84 | Q10        | IC8-10, 14-19, 22-81 | -   |
| -     | -        | -           | -          | IC3-10, 14-19, 22-81 | -   |

REF DESIGNATION NOT USED

DIGITAL SECTION

| IC 230-9 | IC 230-9 | IC 230-9 |
|----------|----------|----------|
| R80      | 510, 5%  | C19      |
| R79      | 5760     | 470 pF   |
| R78      | 100K     | C18      |
| R77      | 1M, 5%   | 470 pF   |
| R76      | 10K      | C17      |
| R75      | 10K      | 470 pF   |
| R74      | 10K      | C16      |
| R73      | 15K      | 470 pF   |
| R72      | 100K     | C15      |
| R71      | 200K     | 470 pF   |
| R70      | 36K      | C14      |
| R69      | 499K     | 470 pF   |
| R68      | 121K     | C13      |
| R67      | 100K     | 470 pF   |
| R66      | 100K     | C12      |
| R65      | 150K     | 470 pF   |
| R64      | 150K     | C11      |
| R63      | 100K     | 470 pF   |
| R62      | 100K     | C10      |
| R61      | 100K     | 470 pF   |
| R60      | 100K     | C9       |
| R59      | 100K     | 470 pF   |
| R58      | 100K     | C8       |
| R57      | 100K     | 470 pF   |
| R56      | 100K     | C7       |
| R55      | 100K     | 470 pF   |
| R54      | 100K     | C6       |
| R53      | 100K     | 470 pF   |
| R52      | 100K     | C5       |
| R51      | 100K     | 470 pF   |
| R50      | 100K     | C4       |
| R49      | 100K     | 470 pF   |
| R48      | 100K     | C3       |
| R47      | 100K     | 470 pF   |
| R46      | 100K     | C2       |
| R45      | 100K     | 470 pF   |
| R44      | 100K     | C1       |
| R43      | 100K     | -        |
| R42      | 100K     | -        |
| R41      | 100K     | -        |
| R40      | 100K     | -        |
| R39      | 100K     | -        |
| R38      | 100K     | -        |
| R37      | 100K     | -        |
| R36      | 100K     | -        |
| R35      | 100K     | -        |
| R34      | 100K     | -        |
| R33      | 100K     | -        |
| R32      | 100K     | -        |
| R31      | 100K     | -        |
| R30      | 100K     | -        |
| R29      | 100K     | -        |
| R28      | 100K     | -        |
| R27      | 100K     | -        |
| R26      | 100K     | -        |
| R25      | 100K     | -        |
| R24      | 100K     | -        |
| R23      | 100K     | -        |
| R22      | 100K     | -        |
| R21      | 100K     | -        |
| R20      | 100K     | -        |
| R19      | 100K     | -        |
| R18      | 100K     | -        |
| R17      | 100K     | -        |
| R16      | 100K     | -        |
| R15      | 100K     | -        |
| R14      | 100K     | -        |
| R13      | 100K     | -        |
| R12      | 100K     | -        |
| R11      | 100K     | -        |
| R10      | 100K     | -        |
| R9       | 100K     | -        |
| R8       | 100K     | -        |
| R7       | 100K     | -        |
| R6       | 100K     | -        |
| R5       | 100K     | -        |
| R4       | 100K     | -        |
| R3       | 100K     | -        |
| R2       | 100K     | -        |
| R1       | 100K     | -        |

NOTES  
 1. UNMARKED RESISTORS ARE 1%  
 2. IC250-IC254 ARE CD4016

CLARKE-HESS COMMUNICATION  
 DR. J. HESS  
 APPR. DTH

MODEL 255 ANALOG SECTION  
 7-28-77 25514

V/I SCALE ADJUSTMENT

100V MAX.  
 COM  
 CHASSIS





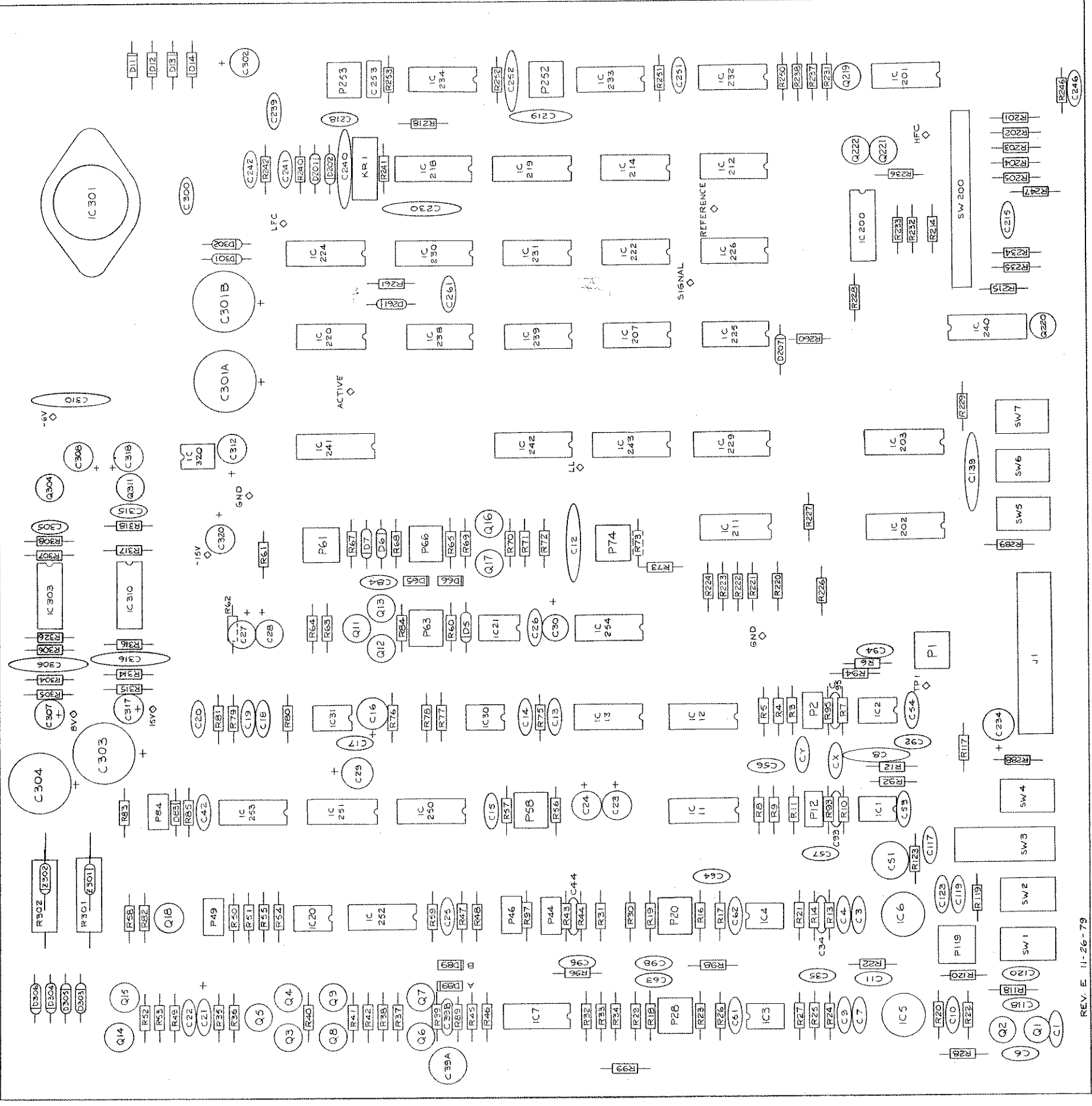

REV. E 11-26-79

DWG NO. 25515

LOCATION DIAGRAM - MAIN PRINTED CIRCUIT BOARD





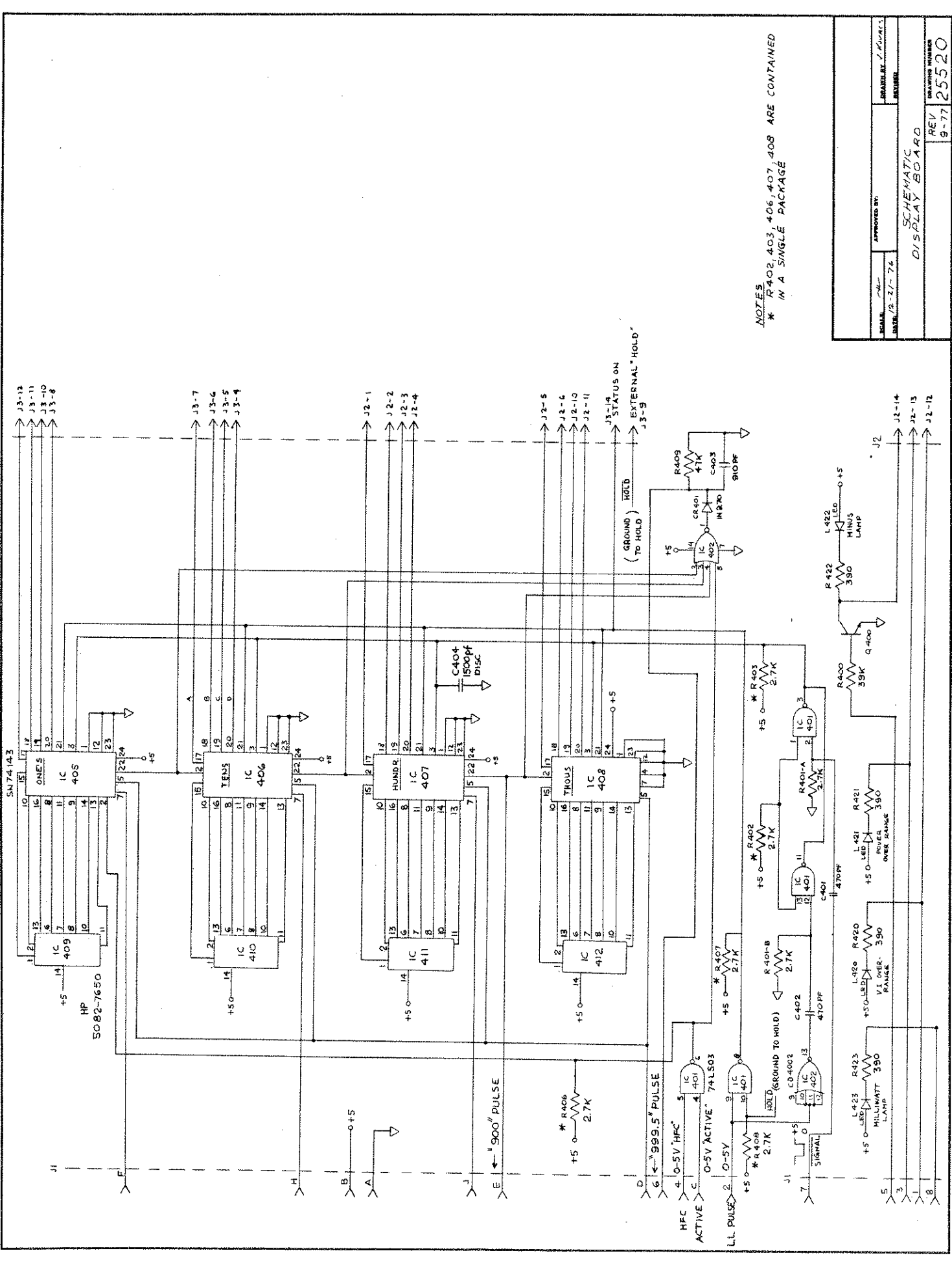

NOTES  
 \* R402, 403, 406, 407, 408 ARE CONTAINED  
 IN A SINGLE PACKAGE

|                |      |             |            |
|----------------|------|-------------|------------|
| SCALE          | DATE | APPROVED BY | DRAWN BY   |
| 1/2 - 2/1 - 76 |      |             |            |
| SCHEMATIC      |      |             | REV        |
| DISPLAY BOARD  |      |             | 9-77 25520 |



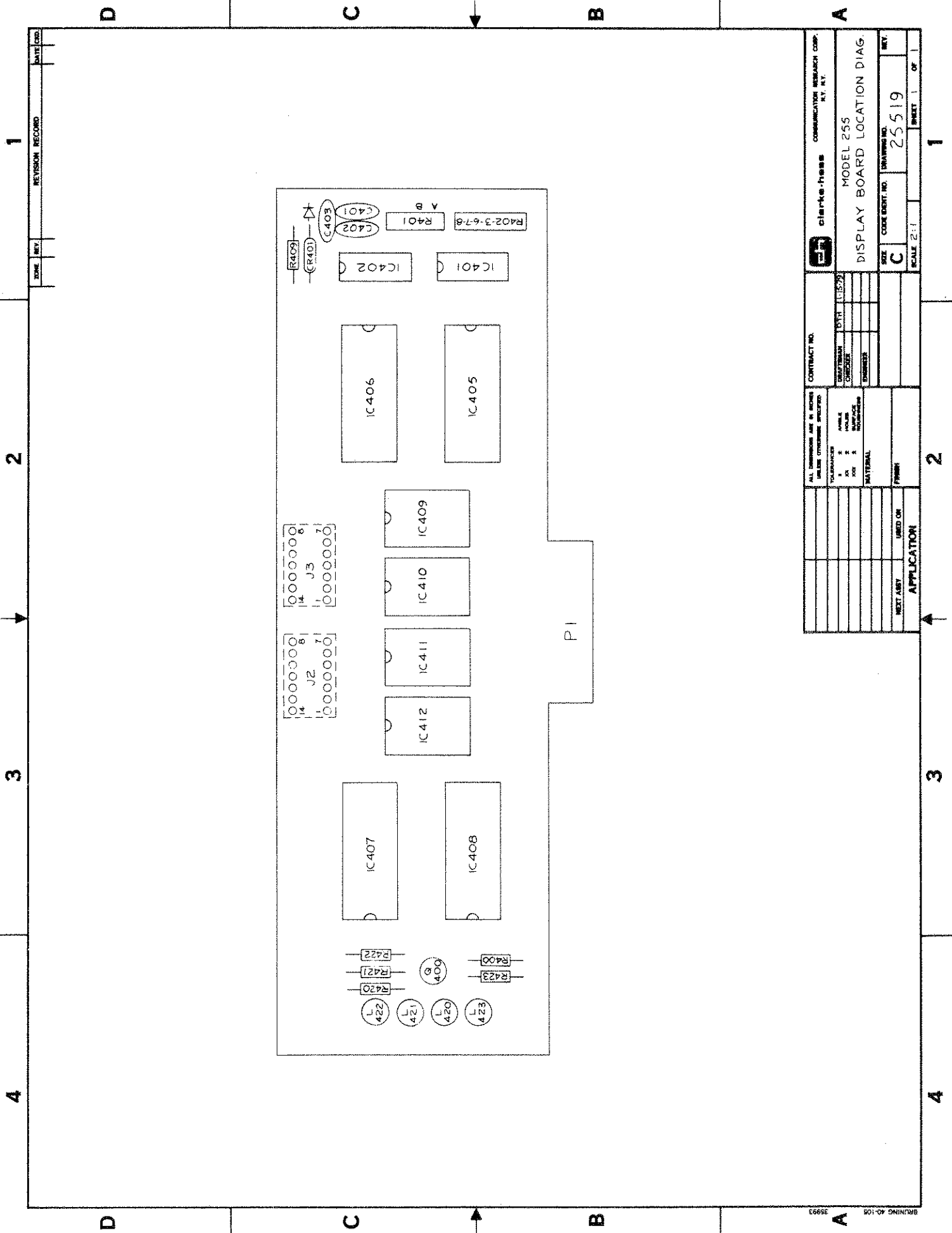

|      |      |                 |      |
|------|------|-----------------|------|
| DATE | REV. | REVISION RECORD | DATE |
|      |      |                 |      |

|                                    |  |  |   |
|------------------------------------|--|--|---|
| CONTRACT NO.<br>CONTRACT NO.       | ALL DIMENSIONS ARE IN INCHES<br>UNLESS OTHERWISE SPECIFIED | TITLE<br>MODEL 255<br>DISPLAY BOARD LOCATION DIAG. | CLIENT'S-FRESS<br>COMMUNICATION RESEARCH CORP.<br>N.Y. N.Y. |
| DRAWN BY<br>CHECKED BY<br>ENGINEER | SCALE<br>2:1   | SHEET NO.<br>25519                                 | OF<br>1   |

|                             |                            |                 |
|-----------------------------|----------------------------|-----------------|
| MATERIAL<br>PARTIAL<br>NONE | USED ON<br>PARTIAL<br>NONE | APPLICATION     |
| PARTIAL<br>NONE             | PARTIAL<br>NONE            | PARTIAL<br>NONE |

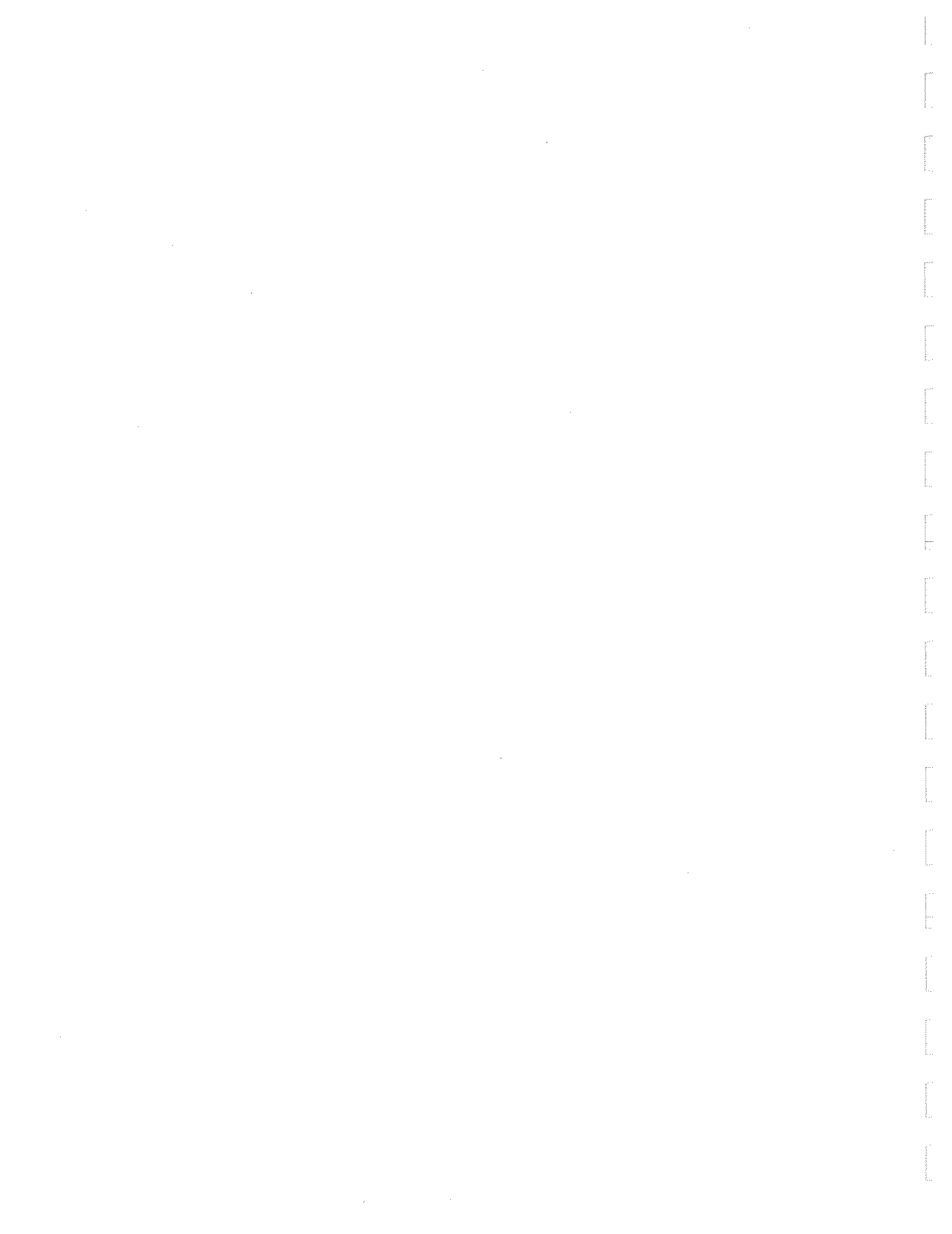



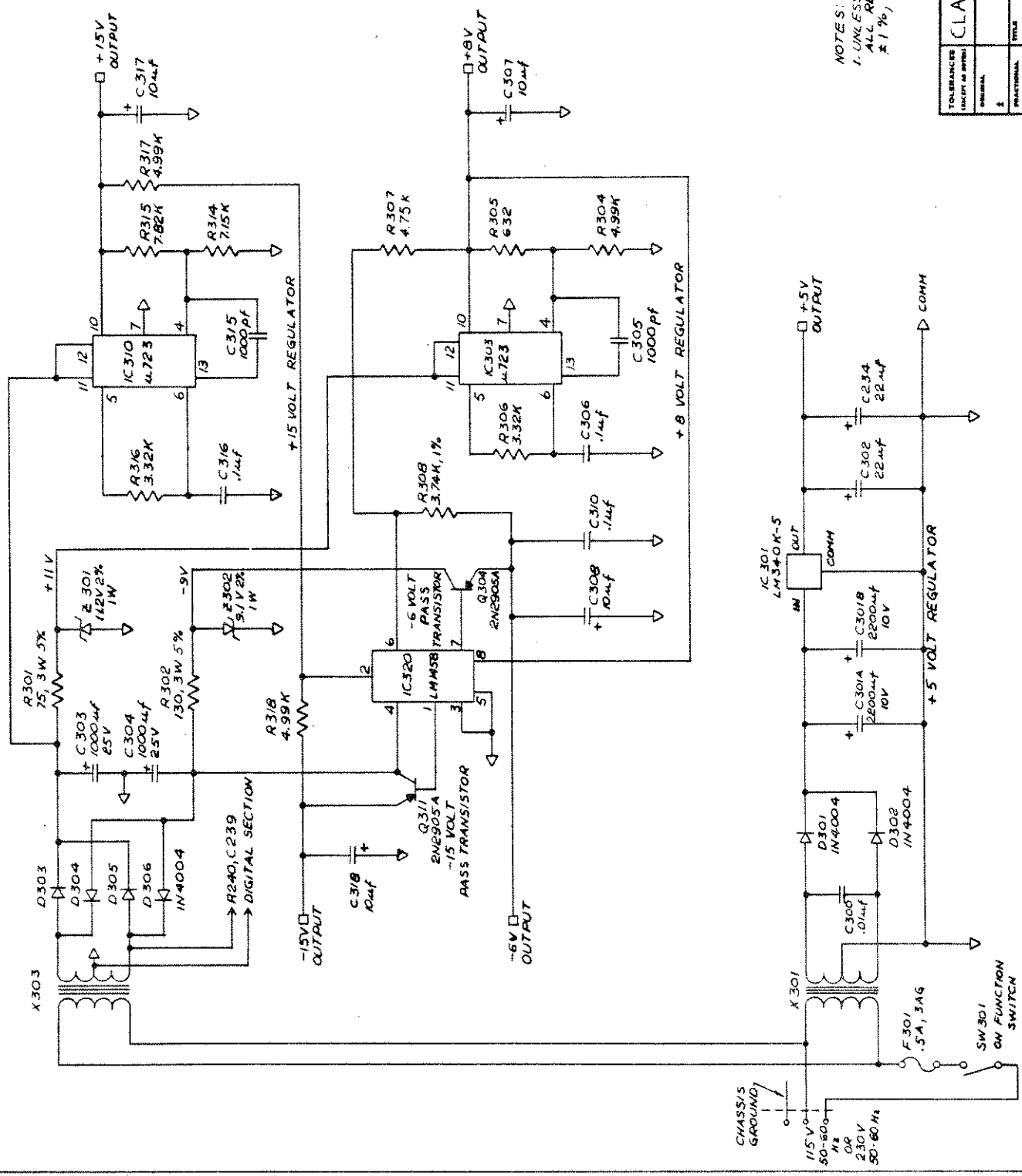

NOTES:  
 1. UNLESS OTHERWISE SPECIFIED  
 ALL RESISTORS ARE IN OHMS,  
 ± 1%, 1/4 W

|  |           |      |            |                               |
|--|-----------|------|------------|-------------------------------|
| TOLERANCES<br>(UNLESS OTHERWISE SPECIFIED) | RESISTORS | ± 1% | CAPACITORS | ± 5%                          |
| ORIGINAL                                   | DATE      | BY   | SCALE      | 1:1                           |
| REVISIONS                                  | NO.       | DATE | BY         | REASON                        |
| 1  |           |      |            | DESIGNED BY J. H. W. A. C. S. |
| 2  |           |      |            | APPROVED BY D. T. H.          |
| SCHEMATIC                                  |           |      |            |                               |
| POWER SUPPLY SECTION                       |           |      |            |                               |
| DATE                                       | REV       | NO.  | REV        | NO.                           |
| 9-2-77                                     | 25518     |      |            |                               |

CLARKE-HESS COMMUNICATION RESEARCH CORP.  
 MADE IN U.S.A.  
 APPROVED BY D.T.H.

